

DISTRIBUTED BY



ENTERPRISES LTD.

1-800-361-5361

Alfa Laval Shutter Valve

Shutter Valve for the Difficult Applications

Concept

Koltek valve is a manually or pneumatically operated valve, designed for use in the food, chemical, pharmaceutical and other industries where valves of hygienic design are needed.

Working principle

A PTFE shutter is operated by means of a handle or an actuator. A spring system presses the shutter against the inside cylindrical surface of the valve body thus ensuring complete tightness.

The air actuated valve can be fitted with ThinkTop® or a laterally fitted indication unit for remote indication of the valve position. The manually operated valve can be fitted with laterally indication units (used for LKLA actuators). The actuator for the valve comes in two versions, single acting or double acting. The single acting actuator operates with one main piston whereas the double acting actuator operates with two main pistons.

Standard Design

The valve consists of a rigid body with an internal cylindrical bore and 3 ports for pipe connection. The two lids have guide rings or bearings for an internal shaft which supports and positions the shutter. The stainless steel handle or the actuator is fitted to turn the shaft.

The actuator consists of a system of cylinders and one or two main pistons interconnected with a toothed bar which interacts with a gear wheel on the valve shaft. The system is insensitive to pressure shocks in the valve.

TECHNICAL DATA

Temperature

Max. temperature: 110°C

Pressure

Max. pressure against shutter: 300 kPa (3 bar)

Max. pressure behind shutter: 1000 kPa (10 bar)

Air pressure for actuator: Max. 800 kPa (8 bar)
Min. 500 kPa (5 bar)

Air Connections

Compressed air:

R 1/8" (BSP), internal thread



PHYSICAL DATA

Materials

Product wetted steel parts: 1.4404 (316L.)

Product wetted seals: Shutter in PTFE
EPDM

Actuator seals: NBR

Actuator functions

Actuator type 630:

- for 25 mm to 76.1 mm valves only
- two positions
- spring/air
- turning angle 1x90°

Actuator type 632:

- two positions
- air/air
- turning angle 1x180°

Sizes 12.7-51mm/DN25-50:

Pneumatic connections

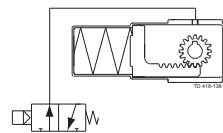
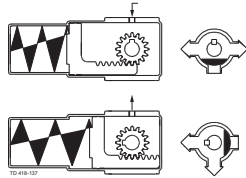

Sizes 12.7-76.1mm/DN25-65:

Pneumatic connections

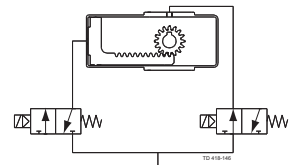
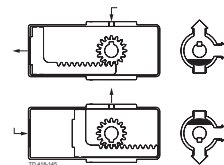

Sizes 63.5-76.1mm/DN65:

Double acting actuator

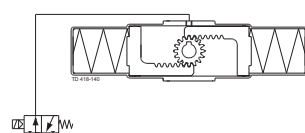
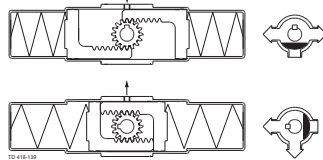

Sizes 101.6mm/DN80100:

Double acting actuator

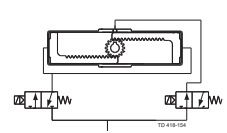
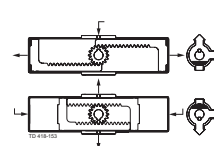

Actuator type 631:

- two positions
- air/air
- turning angle 1x90°

Actuator type 633:

- three positions
- air/air
- turning angles 2x90°

Sizes 12.7-76.1mm/DN25-65:

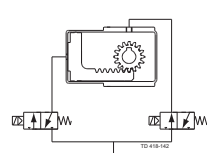
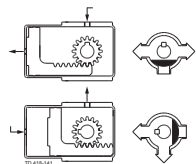

Sizes 12.7-76.1mm/DN25-65:

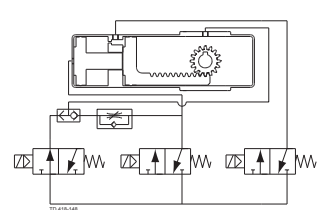
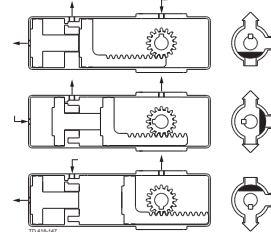

Sizes 101.6mm/DN80100:

Double acting actuator

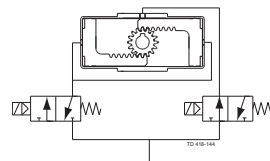
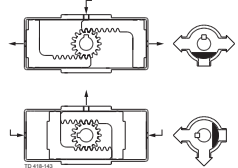

Dimensions (mm)

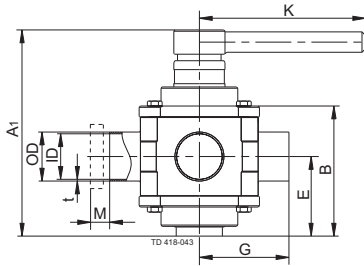

a. MH53 with handle.

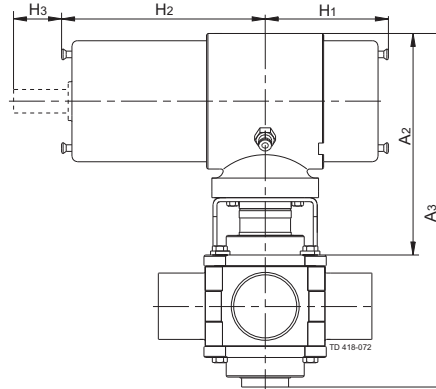

b. MH53 with actuator, type KH631.

Fig. 1. Dimensions.

valves:

Size	25	38	51	63.5	76.1	101.6	25	40	50	65	80	100
	mm	mm	mm	mm	mm	mm	DN	DN	DN	DN	DN	DN
A ₁	116	149	161	179	204	292	116	150	161	204	272	292
B	65	90	102	118	137	195	65	90	102	137	174	195
OD	25.4	38.1	50.8	63.5	76	101.6	29	41	53	70	85	104
ID	22.1	34.8	47.5	60.2	72	97.6	26	38	50	66	81	100
t	1.65	1.65	1.65	1.65	2	2	1.5	1.5	1.5	2	2	2
E	42	56	62	70	80	117	42	56	62	80	107	117
G	55	70	82	105	110	155	64.5	80	82.5	100.5	115.5	130.5
K	130	130	180	180	235	330	130	130	180	235	330	330
M/DIN male							22	22	23	25	25	30
M/SMS male	15	20	20	24	24	35						
Weight (kg)	1.8	3.3	4.8	6.9	10.5	25.0	1.8	3.3	4.8	10.5	22.0	25.0

Actuators

Size		25mm	38mm	51mm	63.5mm	76.1mm	89mm	101.6mm
		DN25	DN40	DN50		DN65	DN80	DN100
A ₂		170	170	170	172	178	194	194
A ₃		233	260	273	290	315	369	389
H ₁	KH630	57	57	57	285	285		
H ₁	KH631	57	57	57	57	57	119	119
H ₁	KH632	95	95	95	95	95	194	194
H ₁	KH633	95	95	95	95	95	281	281
H ₂	KH630	326	326	326	285	285		
H ₂	KH631	119	119	119	119	119	119	119
H ₂	KH632	157	157	157	157	157	194	194
H ₂	KH633	243	243	243	243	243	281	281
H ₃		43	43	43	43	43	43	43

Caution, opening/closing time:

Opening/closing time will be affected by the following:

- The air supply (air pressure).
- The length and dimensions of the air hoses.
- Number of valves connected to the same air hose.
- Use of single solenoid valve for serial connected air actuator functions.
- Product pressure.

Pressure drop/capacity diagrams

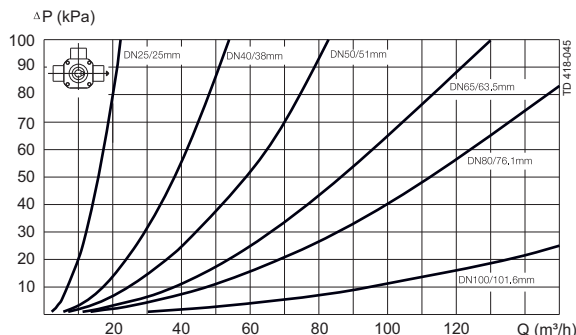
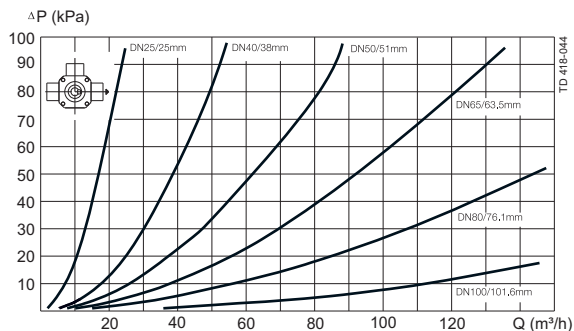

Note!

For the diagram the following applies:

Medium: Water (20°C).

Measurement: In accordance with VDI 2173

Pressure drop can also be calculated in Anytime configurator.

Pressure drop can also be calculated with the following formula:

$$Q = K_v \times \sqrt{\Delta p}$$

Where

Q = Flow in m³/h.

K_v = m³/h at a pressure drop of 1 bar (see table above).

Δp = Pressure drop in bar over the valve.

How to calculate the pressure drop for an ISO 2.5" shut-off valve if the flow is 40 m³/h

2.5" shut-off valve, where K_v = 111 (See table above).

$$Q = K_v \times \sqrt{\Delta p}$$

$$40 = 111 \times \sqrt{\Delta p}$$

$$\Delta p = \left(\frac{40}{111}\right)^2 = 0.13 \text{ bar}$$

(This is approx. the same pressure drop by reading the y-axis above)

Options

- A. Male parts or clamp liners in accordance with required standard.
- B. Control and Indication: IndiTop, ThinkTop or ThinkTop Basic.
- C. Bottom lid for hot water or steam heating.
- D. Bottom fitted indication unit.
- E. Limit stop for MH 52/53.
- F. Pilot valve, type L or T (for actuator type 633). Type L is used when two ThinkTop units are used.
- G. Rebuilding to double acting valve for high viscosity product or quick operation.
- H. Product wetted seals of NBR or FPM..

Note!

For further details, see also instruction IM 70735.

Bottom fitted indication units*

(together with bracket for indication unit)

Actuator type	KH630	KH631	KH632	KH633
Indication unit				
LKLA	1 pcs.	1 pcs.	2 pcs.**	2 pcs.**
(lateral indication unit)				

*) Not possible in combination with heated lid.

***) Not suitable for micro switch.

Note! For all manually operated valves: Use LKLA indication units.

Alfa Laval reserves the right to change specifications without prior notification.

How to contact Alfa Laval

Contact details for all countries are continually updated on our website. Please visit www.alfalaval.com to access the information direct.