

## Ensuring Process Integrity

### LKC-2 Check Valve

#### Application

Check valve LKC-2 is designed for use in sanitary flow installations to prevent reverse flow.

#### Working principle

LKC-2 opens when the pressure below the valve plug exceeds the combination of product and spring pressure above the plug. The valve closes when the combination of product and spring pressure above the valve plug exceeds the pressure below the plug.

#### Standard Design

The valve body is in two parts, assembled by means of a sanitary clamp and sealed with a special seal ring. A guide disc and four legs guide the spring loaded valve plug with an O-ring seal. LKC-2 has welding ends or Tri-Clamp® connections.

#### Materials

Steel parts:	Stainless steel AISI 304 or acid resistant steel AISI 316L
Seal rings:	EPDM rubber.
Finish:	≤32 Ra Electropolished spring

#### Connections

The valve is available with welding or Tri-Clamp connections.

#### Technical data

Required differential pressure for opening the valve when fitted in a vertical pipe, as shown in fig. 3, is approx. 0.87 PSI (0.06 bar).

Max. product pressure:	145 PSI (10 bar)
Max. temperature:	543°F (EPDM).
Min. temperature:	57°F.



LKC-2, check valve.

#### Options

##### Material grades

- A. Product wetted seal rings of Nitrile (NBR) or Fluorinated rubber (FPM).
- B. Eccentric body can be configuration for horizontal installation.

##### Ordering

Please state the following when ordering:

- Size.
- Steel grade, AISI 304 or AISI 316L
- Elastomer if not EPDM

DISTRIBUTED BY

**HARCO**

**ENTERPRISES LTD.**

1-800-361-5361

Pressure drop/capacity diagram

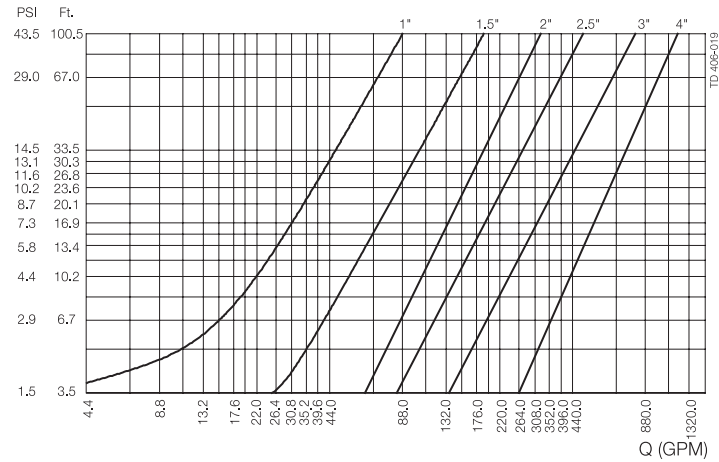

Fig.2. Note:  
Note: Medium: Water (68°F).

Dimensions (in)

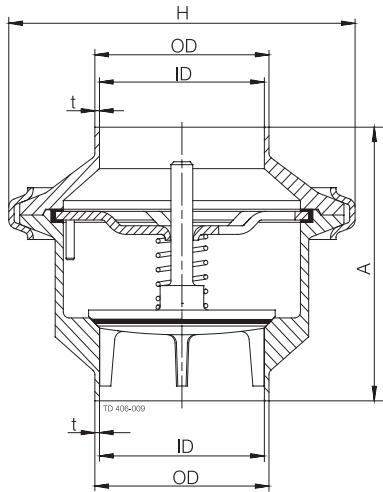

Fig. 4. Dimensions

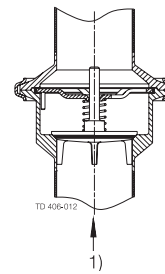

Fig. 3.

1) Indicates preferred installation configuration.  
The four guide legs of the valve cone ensures proper alignment.

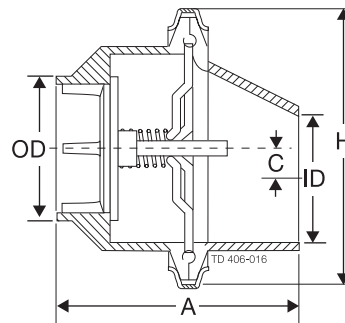

Fig. 5. Dimensions LKC-Drainable

Size	1"	1.5"	2"	2.5"	3"	4"
A	2.46	2.95	3.44	3.74	4.53	6.10
A Tri-Clamp®	4.12	4.61	5.10	5.40	6.19	7.76
OD	1.00	1.50	2.00	2.50	3.00	4.00
ID	0.89	1.40	1.91	2.38	2.83	3.84
t	0.06	0.06	0.06	0.07	0.09	0.09
H	3.23	3.75	4.29	5.39	5.83	6.46
Weight (lbs.)	1.1	1.5	2.2	3.8	5.3	9.5

Size	1"	1.5"	2"	2.5"	3"
A	3.76	3.40	4.10	4.70	5.50
Tri-Clamp®	5.38	5.13	5.80	6.30	7.31
C	0.34	0.40	0.41	0.53	0.65
OD	1.00	1.50	2.00	2.50	3.00
ID	0.89	1.40	1.91	2.38	2.83
t	0.06	0.06	0.06	0.07	0.09
H	3.23	3.75	4.29	5.39	5.83
Weight (lbs.)	1.1	1.5	2.2	3.8	5.3