

DISTRIBUTED BY

**HARCO**  
**ENTERPRISES LTD.**  
1-800-361-5361

## Alfa Laval SX UltraPure Rotary Lobe Pump

The Optimum Choice for High-Purity Processes

### Application

The SX UltraPure range of rotary lobe pumps has been designed for use on wide ranging applications within the Pharmaceutical, Biotechnology and Personal Care industries. Being certified by EHEDG (European Hygienic Equipment Design Group) as fully CIP cleanable to their protocol, and is ideally suited to applications where cleanability and corrosion resistance is paramount.

In addition the SX UltraPure pump range also conforms to USA 3-A Hygienic Standard and all media contacting components are FDA compliant. The SX UltraPure pump operates with a high efficiency, low shear pumping action for assured gentle handling of delicate and sensitive media.

The SX UltraPure pump range is also classified for use in potentially explosive atmospheres under the ATEX Directive 94/9/EC Group II, Categories 2 & 3, with temperature classification T1 to T4.

The SX UltraPure range is compact in size, capable of flow rates up to 115 m<sup>3</sup>/h and pressures up to 15 bar.

### Standard Design

#### Pump Gearbox

The SX UltraPure pump with its conventional lobe pump design concept has a robust stainless steel gearbox, which provides maximum shaft rigidity and easy oil seal replacement. The SX UltraPure range has a universal gearbox design. This gives the flexibility of mounting pumps with the inlet and outlet ports in either a vertical or horizontal plane, by changing the foot and its position.

#### Pump head Construction

The SX UltraPure pump has hygienic design full bore inlet and outlet ports to International Standards, maximising inlet and outlet port efficiency and NPSH characteristics. Vertical porting and unique rotorcase internal profile enhances self-draining and self venting while maintaining optimum volumetric efficiency.

The SX UltraPure pump has four lobe rotors, designed using CFD (Computational Fluid Dynamics) to develop the optimum rotor geometry - possibly the first rotary lobe pump to be developed using this technology. All rotors are rated to 150°C facilitating use with CIP/SIP processes.



 Authorized to carry  
the 3A symbol

## Materials of Construction

Pump gearbox - high quality stainless steel.

Pumphead - product wetted components in 316L - with material traceability 3.1 according to EN 10204. .

Product wetted elastomers of EPDM, MVQ, FPM all FDA conforming. All media contacting elastomers are controlled compression joints, the latest technology where static and dynamic elastomer seals are used to prevent pumped media leaking to atmosphere.

All product wetted elastomers are in compliance with FDA section 21 CFR 177.2600 & section 21 CFR 177.1550 (PTFE). The elastomers are furthermore in compliance with USP Class VI section 87/88 biological reactivity test, at 121°C

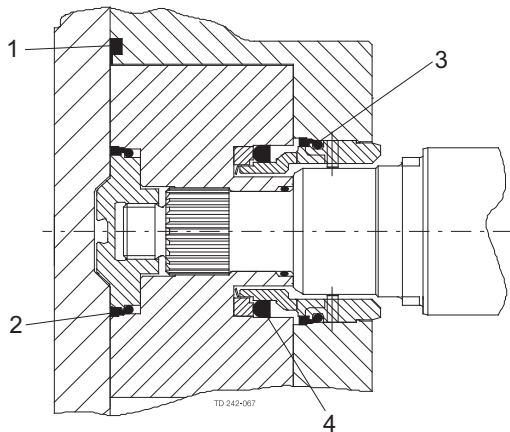

1. Front cover compression joint
2. Spline sealing cup seal
3. Cup seal
4. Squad ring

## Weight

Model	Bare Shaft Pump (kg)	
	Horizontal porting	Vertical porting
SX UltraPure 1/005	15	16
SX UltraPure 1/007	16	17
SX UltraPure 2/013	32	33
SX UltraPure 2/018	33	34
SX UltraPure 3/027	57	59
SX UltraPure 3/035	59	61
SX UltraPure 4/046	107	110
SX UltraPure 4/063	113	116
SX UltraPure 5/082	155	155
SX UltraPure 5/115	165	165
SX UltraPure 6/140	278	278
SX UltraPure 6/190	290	290
SX UltraPure 7/250	-	340
SX UltraPure 7/380	-	362

## Shaft Seal Options

- Single or single flush/quench (steam barrier for aseptic application) R00 type mechanical seals.
- Double R00 type mechanical seal for flush.

All sealing options are fully front loading and fully interchangeable without the need for additional housings or pump component changes. Specialised seal setting of the mechanical seal is not required as the seal is dimensionally set on assembly. This feature further enhances fast and efficient on-site seal interchangeability.

## Materials for Mechanical Seals

As standard the SX UltraPure is supplied with EHEDG compliant Silicon Carbide/Silicon Carbide seal faces avoiding any risk of potential extractable contamination.

## Pump Sizing

In order to correctly size a rotary lobe pump some essential information is required. Provision of this information listed below enables our Technical Support personnel to obtain the optimum pump selection.

## Product/Fluid Data

- Fluid to be pumped
- Viscosity
- SG/Density
- Pumping temperature, minimum, normal and maximum
- Cleaning in Place temperature(s), minimum, normal and maximum

## Performance Data

- Flow rate, minimum, normal and maximum
- Discharge head/pressure (closest to pump outlet)
- Suction condition

## Standard Specification Options

- Screwed male inlet and outlet ports to DIN11851, SMS, RJT, Triclamp for ASME, DIN 32676 Clamp, DIN 11864-1 (Union) Form A, DIN 11864-2 (Flange) Form A or DIN 11864-3 (Clamp) Form A.
- Heating/Cooling Jacket for Rotorcase Cover.
- Product wetted surface finish electropolished to  $Ra \leq 0.38 \mu m$ .
- Passivated surface.
- Surface finish measurement with certificate.
- Hydrostatic testing with certificate.
- ATEX compliance.
- Complete pump unit comprising: Pump + stainless steel baseplate + coupling with guard + Geared electric motor suitable for (or supplied with) frequency speed control or manual variable speed drive (advise motor enclosure and electrical supply).
- Low delta ferrite material for product wetted components.
- High alloy materials for product wetted components i.e AL6XN or Titanium.

## Q-doc

### Standard documentation package:

- Declaration of compliance with Regulation (EC) No.: 1935/2004
- Declaration of compliance to EN 10204 type 3.1 (MTR)
- Declaration of compliance to the U.S. Food & Drug Administration CFR 21 (non-metallic parts)
- Declaration of compliance to the U.S. Pharmacopeia (Elastomers and polymers)
- TSE (Transmissible Spongiform Encephalopathy) / ADI (Animal Derivative Ingredient) declaration
- Declaration of surface finish compliance
- Declaration of passivation and electro polishing (if specified)
- 3.1 certification in accordance to EN10204
- Pump performance test certificate

### Optional documentation:

- Hydrostatic test certificate
- Surface measurement report

## Working Principle

The positive displacement of the SX UltraPure pump is provided by non-contacting, contra rotating four lobe rotors within a fully swept pump chamber. All SX UltraPure pumps are capable of bi-rotational flow without modification.

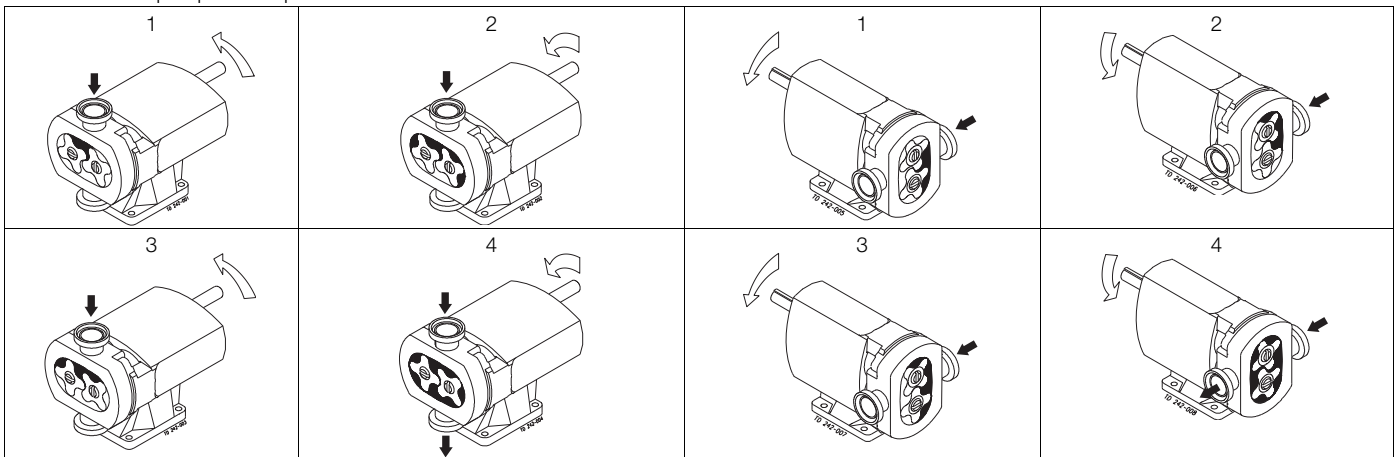

## Flows/Pressures/Connections

SX Model	Displacement			Inlet and Outlet Connection Size		Differential Pressure (see note 1)		Maximum Speed
	Litre/rev	Imp gall/100 rev	US gall/100 rev	mm	in	bar	psi	rev/min
SX UltraPure 1/005	0.05	1.11	1.32	25	1	12	175	1200
SX UltraPure 1/007	0.07	1.54	1.85	40	1.5	7	100	1200
SX UltraPure 2/013	0.128	2.82	3.38	40	1.5	15	215	1000
SX UltraPure 2/018	0.181	3.98	4.78	50	2	7	100	1000
SX UltraPure 3/027	0.266	5.85	7.03	50	2	15	215	1000
SX UltraPure 3/035	0.35	7.70	9.25	65	2.5	7	100	1000
SX UltraPure 4/046	0.46	10.12	12.15	50	2	15	215	1000
SX UltraPure 4/063	0.63	13.86	16.65	65	2.5	10	145	1000
SX UltraPure 5/082	0.82	18.04	21.67	65	2.5	15	215	600
SX UltraPure 5/115	1.15	25.30	30.38	80	3	10	145	600
SX UltraPure 6/140	1.40	30.80	36.99	80	3	15	215	500
SX UltraPure 6/190	1.90	41.80	50.20	100	4	10	145	500
SX UltraPure 7/250	2.50	55.00	66.05	100	4	15	215	500
SX UltraPure 7/380	3.80	83.60	100.40	150	6	10	145	500

**Note 1.** These pressure ratings may vary for pumps with certain threaded connections.

**Bareshaft Pump Dimensions**

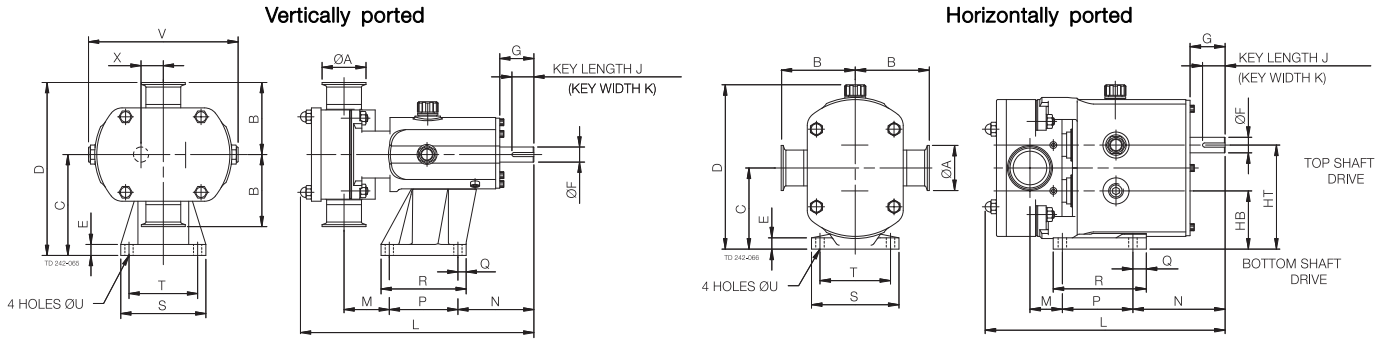

**Vertically ported**

All dimensions in mm

PUMP	A	B	C	D	E	F	G	J	K	L	M	N	P	Q	R	S	T	U	V	X
SX UltraPure 1/005	25	95	113	208	15	16	40	30	5	281	53	100	80	22	114	104	80	10	174	23.5
SX UltraPure 1/007	40	95	113	208	15	16	40	30	5	294	60	100	80	22	114	104	80	10	174	23.5
SX UltraPure 2/013	40	105	147	252	15	22	50	32	6	325	59	111	100	12	124	124	100	12	213	32.5
SX UltraPure 2/018	50	105	147	252	15	22	50	32	6	341	66	111	100	12	124	124	100	12	213	32.5
SX UltraPure 3/027	50	125	175	300	22	28	61	40	8	431	71	142	155	15	185	155	125	14	246	37.5
SX UltraPure 3/035	65	125	175	300	22	28	61	40	8	447	77	142	155	15	185	155	125	14	246	37.5
SX UltraPure 4/046	50	150	213	363	25	38	80	63	10	514	74	174	200	17	234	184	150	14	301	49.5
SX UltraPure 4/063	65	150	213	363	25	38	80	63	10	533	81	174	200	17	234	184	150	14	301	49.5
SX UltraPure 5/082	65	175	256.5	431.5	30	45	110	70	14	599	61	264	200	20	240	220	180	14	344	60
SX UltraPure 5/115	80	175	256.5	431.5	30	45	110	70	14	629	81	264	200	20	240	220	180	14	344	60
SX UltraPure 6/140	80	190	295	485	30	48	110	70	14	687	77	267	260	20	300	250	210	14	400	70
SX UltraPure 6/190	100	190	295	485	30	48	110	70	14	715	89	267	260	20	300	250	210	14	400	70
SX UltraPure 7/250	100	205	365	570	30	60	110	90	18	763	94	288	280	25	330	290	240	18	475	81.5
SX UltraPure 7/380	150	205	365	570	30	60	110	90	18	817	121	288	280	25	330	290	240	18	475	81.5

**Horizontally ported**

All dimensions in mm

PUMP	A	B	C	D	E	F	G	HB	HT	J	K	L	M	N	P	Q	R	S	T	U
SX UltraPure 1/005	25	95	90.5	189	10	16	40	67	114	30	5	281	29	124	80	10	100	100	80	10
SX UltraPure 1/007	40	95	90.5	189	10	16	40	67	114	30	5	294	36	124	80	10	100	100	80	10
SX UltraPure 2/013	40	105	115	233	15	22	50	82.5	147.5	32	6	325	39	131	100	19	132	124	100	12
SX UltraPure 2/018	50	105	115	233	15	22	50	82.5	147.5	32	6	341	46	131	100	19	132	124	100	12
SX UltraPure 3/027	50	125	137.5	272	18	28	60	100	175	40	8	431	68	175	125	30	181	154	125	14
SX UltraPure 3/035	65	125	137.5	272	18	28	60	100	175	40	8	447	74	175	125	30	181	154	125	14
SX UltraPure 4/046	50	150	163	325	20	38	80	113.5	212.5	63	10	514	74	225	150	35	202	184	150	14
SX UltraPure 4/063	65	150	163	325	20	38	80	113.5	212.5	63	10	533	81	225	150	35	202	184	150	14
SX UltraPure 5/082	65	175	195	376	20	45	110	135	255	70	14	599	46	279	180	35	275	210	180	14
SX UltraPure 5/115	80	175	195	376	20	45	110	135	255	70	14	626	66	279	180	35	275	210	180	14
SX UltraPure 6/140	80	190	225	429	20	48	110	155	295	70	14	687	78	266	260	40	370	220	190	14
SX UltraPure 6/190	100	190	225	429	20	48	110	155	295	70	14	715	90	266	260	40	370	220	190	14

DISTRIBUTED BY

