



FLOWave SAW flowmeter

- No obstacles inside the measuring tube, compact, lightweight and low energy consumption
- Conforms to hygienic requirements, CIP/SIP compatible
- Ideal for liquids with low or no conductivity
- Digital communication, parameterisation via Communicator, display
- Optional: ATEX/IECEX certification, II 3G/D

Product variants described in the data sheet may differ from the product presentation and description.

Can be combined with

	Type 8802 ELEMENT continuous control valve systems - overview	▶
	Type 8619 multiCELL - Multi-channel and multi-function transmitter/controller	▶
	Type 8647 AirLINE SP – electro-pneumatic automation system	▶
	Type ME43 Fieldbus gateway	▶

Type description

The Type 8098 flowmeter is part of the FLOWave product range. It is based on SAW (Surface Acoustic Waves) technology and is mainly designed for applications with the highest hygienic demands. This is achieved by using:

- suitable stainless steel materials
- a measuring tube free of any wetted parts except for the actual tube
- the ideal outer hygienic design.

FLOWave offers a range of integrated functions, including the advantages of flexibility, ease of cleaning, compact dimensions, lightweight, easy installation and handling, and is compliant with numerous standards.

Optimal measurement results can be achieved with homogeneous liquids, free of air and solid particles. For liquids with high viscosity, an integrated viscosity compensation can be activated. Gas and steam cannot be measured; however, their flow does not have any negative effect on the device or its operation and other liquids flowing through afterwards are measured correctly as before.

Beside volume flow, a density measurement optional feature is available. With this option, the mass flow is calculated based on volume flow and density measurements.

Special functions derived from further process values (differentiation factor (DF), acoustic transmission factor) offer additional information about the particular liquid in use (for details, see chapter **"7.2. Special functions"** on page 30).

Table of contents

1. General technical data	4
1.1. About the device.....	4
1.2. All variants	4
1.3. FLOWave L flowmeter.....	9
With or without industrial communication	9
With industrial communication (Ethernet variant)	11
1.4. FLOWave S flowmeter	13
2. Approvals	15
2.1. Certifications.....	15
2.2. Certificates.....	16
2.3. Pressure equipment directive	16
Device used on a pipe	16
3. Materials	16
3.1. Chemical Resistance Chart – Bürkert resistApp.....	16
3.2. Material specifications	17
FLOWave L flowmeter without industrial communication	17
FLOWave L flowmeter with industrial communication	18
FLOWave S flowmeter	19
4. Dimensions	20
4.1. Transmitter of the FLOWave L flowmeter without industrial communication	20
4.2. Transmitter of the FLOWave L flowmeter with industrial communication (Ethernet variant)	20
4.3. Transmitter of the FLOWave S flowmeter	20
4.4. Flowmeter with clamp process connection	21
4.5. Flowmeter with aseptic collar flange (BF).....	23
4.6. Flowmeter with aseptic collar clamp (BKS)	24
4.7. Flowmeter with thread connection	25
5. Performance specifications	25
5.1. Medium temperature diagram	25
5.2. Measurement deviation table	26
5.3. Refresh time table.....	26
6. Product installation	27
6.1. Installation notes.....	27
6.2. Selection of the nominal diameter	27
6.3. Mounting options.....	28
FLOWave L flowmeter.....	28
FLOWave S flowmeter	28
7. Product operation	29
7.1. Measuring principle	29
7.2. Special functions	30
8. Product design and assembly	31
8.1. Product assembly	31
9. Product accessories	32

10. Ordering information

32

10.1. Bürkert eShop – Easy ordering and quick delivery.....	32
10.2. Recommendation regarding product selection	32
10.3. Bürkert product filter.....	33
10.4. Bürkert 3D Model - Interactive Animation	33
10.5. Ordering chart FLOWave L flowmeter with or without industrial communication	34
Clamp process connection acc. to DIN 32676 series A for pipe acc. to DIN 11866 series A (DIN 11850)	34
Clamp process connection acc. to DIN 32676 series B for pipe acc. to DIN 11866 series B (ISO 1127).....	35
Clamp process connection acc. to DIN 32676 series C for pipe acc. to DIN 11866 series C (ASME BPE)	36
Thread process connection acc. to DIN 11851 series A for pipe acc. to DIN 11866 series A (DIN 11850)	37
10.6. Ordering chart FLOWave S flowmeter	38
Clamp process connection acc. to DIN 32676 series A for pipe acc. to DIN 11866 series A (DIN 11850)	38
Clamp process connection acc. to DIN 32676 series B for pipe acc. to DIN 11866 series B (ISO 1127).....	39
Clamp process connection acc. to DIN 32676 series C for pipe acc. to DIN 11866 series C (ASME BPE)	40
Thread process connection acc. to DIN 11851 series A for pipe acc. to DIN 11866 series A (DIN 11850)	41
10.7. Ordering chart accessories.....	42

1. General technical data

1.1. About the device

The flowmeter Type 8098 consists of:

- either a flow sensor Type S097 and a FLOWave L transmitter (variant FLOWave L flowmeter), which is available with or without industrial communication (the FLOWave L variant with industrial communication, recognisable by the two M12 circular female connectors and the M12 circular male connector, is called the Ethernet variant.)



- or a flow sensor Type S097 and a FLOWave S transmitter (variant FLOWave S flowmeter)



1.2. All variants

Note:

- The following data applies to all variants mentioned above.
- In the following table, the term “full scale” refers to full scale of volume flow rate, i.e. the flow rate corresponding to 10 m/s flow velocity.

Product properties

Material

Please make sure the device materials are compatible with the fluid you are using.

Detailed information can be found in chapter [“3.1. Chemical Resistance Chart – Bürkert resistApp” on page 16.](#)

Detailed information on the materials can be found in chapter [“3.2. Material specifications” on page 17.](#)

Non wetted parts

Sensor housing

- For sensor with process connection \leq DN 50/2": stainless steel 304/1.4301
- For sensor with process connection $>$ DN 50/2": stainless steel 316L/1.4435

Wetted parts

Measurement tube and process connection Stainless steel 316L/1.4435 with low delta ferrite content

Surface quality

Measurement tube (inner surface)

- $R_a < 0.8 \mu\text{m}$ (30 $\mu\text{in.}$) or
- $R_a < 0.4 \mu\text{m}$ (15 $\mu\text{in.}$) (electro-polished) according to ISO 4288

Dimensions

Detailed information can be found in chapter [“4. Dimensions” on page 20.](#)

Measuring range

Volume flow rate measurement	0...1.7 m ³ /h up to 0...200 m ³ /h Detailed information can be found in chapter “10.5. Ordering chart FLOWave L flowmeter with or without industrial communication” on page 34 or “10.6. Ordering chart FLOWave S flowmeter” on page 38 .
Density measurement ¹⁾	0.8...1.3 g/cm ³ (inactive by default, selectable upon request)
Mass flow rate measurement ¹⁾	0...1 360 kg/h up to 0...260 000 kg/h (inactive by default, selectable upon request)
Temperature measurement	-20...+140 °C (-4...+284 °F)
Special function	Active by default, deselectable upon request. <ul style="list-style-type: none"> • ATF: acoustic transmission factor • DF: differentiation factor Detailed information can be found in chapter “7.2. Special functions” on page 30 .

Performance data

Volume flow rate measurement

Under reference conditions i.e. measuring fluid = water free from gas bubbles and solids, ambient and water temperature = 23 °C ± 1 °C (73.4 °F ± 1.8 F), and short refresh time, while maintaining turbulent or laminar flow profile, with the minimum inlet (40 x DN) and outlet (1 x DN) distances and the appropriate internal diameter of the pipes. Deviation from reference conditions can be adjusted through the use of a built-in correction K factor adjustment or Teach-in Procedure.

Measurement deviation	<ul style="list-style-type: none"> • From 10 % of full scale up to full scale: ±0.4 % of the measured value • From 1 % of full scale up to 10 % of full scale: ±0.08 % of full scale Detailed information can be found in chapter “5.2. Measurement deviation table” on page 26 .
Repeatability	<ul style="list-style-type: none"> • From 10 % of full scale up to full scale: ±0.2 % of the measured value • From 1 % of full scale up to 10 % of full scale: ±0.04 % of full scale
Refresh time	Selectable between very short, short and long Detailed information can be found in chapter “5.3. Refresh time table” on page 26 .

Density measurement

As an option¹⁾

Under reference conditions i.e. measuring fluid = water free from gas bubbles and solids, ambient and water temperature = 23 °C ± 1 °C (73.4 °F ± 1.8 F). Deviations from reference conditions, especially exposure of the device to temperatures above 90 °C can be adjusted through the use of a built in adjustment procedure (see [user manual Type 8098](#) ▶).

Measurement deviation	<ul style="list-style-type: none"> • Standard product adjustment: ±2 % of the measured value • After Teach-In: ±1 % of the measured value (at teach-in density value)
Repeatability	±1 % of the measured value
Refresh time	Selectable between very short, short and long Detailed information can be found in chapter “5.3. Refresh time table” on page 26 .

Mass flow rate measurement

As an option¹⁾

Under reference conditions i.e. measuring fluid = water free from gas bubbles and solids, ambient and water temperature = 23 °C ± 1 °C (73.4 °F ± 1.8 F), and short refresh time, while maintaining turbulent or laminar flow profile, with the minimum inlet (40 x DN) and outlet (1 x DN) distances and the appropriate internal diameter of the pipes. Deviation from reference conditions, can be adjusted through the use of a built-in correction K factor adjustment or Teach-in Procedure.

Measurement deviation	<ul style="list-style-type: none"> • Standard K-factor: <ul style="list-style-type: none"> – From 10 % of full scale up to full scale: ±2.4 % of the measured value – From 1 % of full scale up to 10 % of full scale: ±(2 % of the measured value + 0.08 % of full scale) • After Teach-In: <ul style="list-style-type: none"> – From 10 % of full scale up to full scale: ±1.4 % of the measured value at teach-in density and mass flow rate values – From 1 % of full scale up to 10 % of full scale: ±(1 % of the measured value + 0.08 % of full scale) at teach-in density and mass flow rate values Detailed information can be found in chapter “5.2. Measurement deviation table” on page 26 .
Repeatability	<ul style="list-style-type: none"> • From 10 % of full scale up to full scale: ±1.2 % of the measured value • From 1 % of full scale up to 10 % of full scale: ±(1 % of the measured value + 0.04 % of full scale)
Refresh time	Selectable between very short, short and long Detailed information can be found in chapter “5.3. Refresh time table” on page 26 .

Temperature measurement

Measurement deviation	<ul style="list-style-type: none"> For $T^{\circ} \leq 100^{\circ}\text{C}$ ($+212^{\circ}\text{F}$): $\pm 1^{\circ}\text{C}$ ($+1.8^{\circ}\text{F}$) For 100°C ($+212^{\circ}\text{F}$) $< T^{\circ} < 140^{\circ}\text{C}$ ($+284^{\circ}\text{F}$): $\pm 1.5\%$
Refresh time	Approx. 0.1 s

Electrical data

Operating voltage	<ul style="list-style-type: none"> 12...35 V DC filtered and regulated Tolerance: $\pm 10\%$ Connection to main supply: permanent (through external SELV (Safety Extra Low Voltage) and LPS (Limited Power Source) power supply)
Power source (not supplied)	Limited power source according to UL/EN 60950-1 standards or limited energy circuit according to UL/EN 61010-1 §9.4
DC reverse polarity protection	Yes

Voltage supply cable

For cable gland	<ul style="list-style-type: none"> 0.2...1.5 mm² cross-section In nickel plated brass: <ul style="list-style-type: none"> Cable with maximum operating temperature greater than $+80^{\circ}\text{C}$ ($+176^{\circ}\text{F}$) 5...14 mm diameter, shielded cable In stainless steel: <ul style="list-style-type: none"> Cable with maximum operating temperature greater than $+80^{\circ}\text{C}$ ($+176^{\circ}\text{F}$) 6...12 mm diameter, shielded cable
For 5-pin M12 circular male connector (A-coded)	<ul style="list-style-type: none"> Cable with maximum operating temperature greater than $+80^{\circ}\text{C}$ ($+176^{\circ}\text{F}$) 3...6.5 mm diameter, shielded cable, 0.75 mm² cross-section to connect to 5-pin M12 female connector (A-coded, not supplied)
For 4-pin M12 circular female connector (D-coded)	<ul style="list-style-type: none"> Cable with maximum operating temperature greater than $+80^{\circ}\text{C}$ ($+176^{\circ}\text{F}$) 5e / CAT-5 min. category, 100 m max. length, shielded conductor with minimum STP

Medium data

Fluid	<p>Non-dangerous liquids complying with article 4, §1 of 2014/68/EU directive. Detailed information can be found in chapter "2.3. Pressure equipment directive" on page 16.</p> <p>By default the FLOWave flowmeter is set for a fluid with a sound velocity²⁾</p> <ul style="list-style-type: none"> between 1000 m/s and 2000 m/s for process connection DN 08, $\frac{3}{8}$" and $\frac{1}{2}$" between 800 m/s and 2300 m/s for process connection DN ≥ 15 or $\geq \frac{3}{4}$"
Fluid temperature	<ul style="list-style-type: none"> $-20...+110^{\circ}\text{C}$ ($-4...+230^{\circ}\text{F}$). The maximum fluid temperature can be restricted by the ambient operating temperature. Max. conditions for sterilisation process: up to $+140^{\circ}\text{C}$ ($+284^{\circ}\text{F}$) ($+130^{\circ}\text{C}$ ($+266^{\circ}\text{F}$) for ATEX/IECEx variant) for max. 60 min Maximum temperature gradient: 10°C/s (18°F/s) (measured by the integrated sensor on the device)

Fluid pressure (max.)

DN / Pipe standard	DIN 11850	ISO 1127	ASME BPE	SMS 3008
DN 08, $\frac{3}{8}$ ", $\frac{1}{2}$ "	PN 25	PN 25	PN 25	–
DN 15, $\frac{3}{4}$ ", DN 25, 1", $1\frac{1}{2}$ "	PN 25	PN 25	PN 25	PN 25
DN 40	PN 25	PN 16	–	PN 25
DN 50, 2"	PN 16	PN 16	PN 16	PN 16
DN 65, $2\frac{1}{2}$ ", DN 80, 3"	PN 10	PN 10	PN 10	–

Process/Pipe connection & communication**Process connection size / pipe size³⁾ according to**

DIN 32676 series A / DIN 11850	Clamp: DN 08, DN 15, DN 25, DN 40, DN 50, DN 65 and DN 80
DIN 32676 series B / ISO 1127	Clamp: DN 08, DN 15, DN 25, DN 40, DN 50, DN 65 and DN 80
DIN 32676 series C / ASME BPE	Clamp: 3/8", 1/2", 3/4", 1", 1 1/2", 2", 2 1/2" and 3"
DIN 11864-2 form A series A / DIN 11850	Aseptic collar flange (BF) ⁴⁾ : DN 15, DN 25, DN 40, DN 50, DN 65 and DN 80
DIN 11864-2 form A series B / ISO 1127	Aseptic collar flange (BF) ⁴⁾ : DN 08, DN 15, DN 25, DN 40, DN 50, DN 65 and DN 80
DIN 11864-2 form A series C / ASME BPE	Aseptic collar flange (BF) ⁴⁾ : 1/2", 3/4", 1", 1 1/2" and 2"
DIN 11864-3 form A series A / DIN 11850	Aseptic collar clamp (BKS) ⁴⁾ : DN 15, DN 25, DN 40 and DN 50
DIN 11864-3 form A series B / ISO 1127	Aseptic collar clamp (BKS) ⁴⁾ : DN 08, DN 15, DN 25, DN 40 and DN 50
DIN 11864-3 form A series C / ASME BPE	Aseptic collar clamp (BKS) ⁴⁾ : 1/2", 3/4", 1", 1 1/2" and 2"
SMS 3017 / SMS 3008	Clamp: DN 25, DN 40 and DN 50
DIN 11851 series A / DIN 11850	Thread: DN 65 and DN 80
Device status	LED light ring according to NAMUR NE 107

Approvals and Certificates**Directives**

CE directive	The applied standards, which verify conformity with the EU Directives, can be found on the EU Type Examination Certificate and/or the EU Declaration of conformity (if applicable).
Pressure equipment directive	Complying with article 4, paragraph 1 of 2014/68/EU directive Detailed information on the pressure equipment directive can be found in chapter "2.3. Pressure equipment directive" on page 16.

Certification	<ul style="list-style-type: none"> • EHEDG (Type EL CLASS I)⁵⁾ • 3A (28-06) • On request: <ul style="list-style-type: none"> – UL-Listed for USA and Canada – ATEX/IECEX
Certificate	<ul style="list-style-type: none"> • FDA declaration of conformity • Inspection certificate 3.1 • Certification of compliance ASME BPE • Fluidic test report (test regarding volumetric flow rate or volume and mass flow rates, if density and mass flow rate option chosen) • On request: <ul style="list-style-type: none"> – Calibration certificate (volumetric flow rate, volume and mass flow rates and density) – USP class VI declaration – ECR1935/2004 declaration – CRN 0C21751 declaration⁶⁾ – Test report 2.2 – Certification of conformity for the surface quality DIN 4762, EN ISO 4287, EN ISO 4288 – Certification of conformity for passivation and electro-polishing processes – MTBF (Mean Time Between Failures) manufacturer declaration

Environment and installation**Ambient temperature**

Operation	Depends on the fluid temperature. Detailed information can be found in chapter "5.1. Medium temperature diagram" on page 25.
Storage	-20...+70 °C (-4...+158 °F)
Relative air humidity	≤ 85 %, without condensation
Height above sea level	Max. 2000 m
Operating condition	Continuous
Equipment mobility	Fixed device

Application range	Indoor and outdoor (protect the device against electromagnetic interference, ultraviolet rays and, when installed outdoors, against the effects of climatic conditions)
Degree of protection ^{7.)}	IP65, IP67 (according to IEC/EN 60529), NEMA 4X (according to NEMA250), if the product is wired and if the cable glands are tightened and the covers are screwed tight. Unused cable glands must be sealed with the stopper gaskets provided (mounted upon delivery of the product). An unused M12 fixed connector must be protected by the screwed plug.
Installation category	Category I according to UL/EN 61010-1
Pollution degree	Degree 2 according to UL/EN 61010-1

1.) Only for a flowmeter FLOWave with a process connection size of DN 08...DN 50 or ½"...2", pending for the other dimensions

2.) Customer specific setting on request. Please contact your Bürkert partners!

3.) Please refer to the dimension table of the sensor, see chapters "4.4. Flowmeter with clamp process connection" on page 21, "4.5. Flowmeter with aseptic collar flange (BF)" on page 23, "4.6. Flowmeter with aseptic collar clamp (BKS)" on page 24, and "4.7. Flowmeter with thread connection" on page 25.

4.) In German: BF = Bundflansch, BKS= Bundklemmstutzen

5.) The EHEDG compliance for :

- clamp connection according to DIN 32676 is only valid if used in combination with EHEDG-compliant gaskets from Combifit International B.V.
- threaded connection according to DIN 11851 is only valid if used in combination with EHEDG-compliant gaskets from
 1. Kieselmann GmbH, Germany (ASEPTO-STAR k-flex upgrade gaskets) or
 2. Siersema Componenten Service (S.K.S.) B.V. (Netherlands SKS gasket set DIN 11851 EHEDG with EPDM or FKM inner gasket)

6.) Only for a flowmeter with a process connection size of ¾"...2", pending for the other dimensions

7.) Not evaluated by UL, only IP64 is evaluated by the ATEX/IECEx notified/certification body.

1.3. FLOWave L flowmeter

The FLOWave L flowmeter is available in four variants of the transmitter:

- Stainless steel transmitter with nickel plated brass cable glands and M12 circular male connector
- Stainless steel transmitter with stainless steel cable glands and M12 circular male connector (full stainless steel variant)
- Stainless steel transmitter with stainless steel M12 circular female and male connectors and industrial communication (Ethernet variant)
- Stainless steel transmitter with stainless steel cable glands and M12 circular male connector (ATEX/IECEX variant).



With or without industrial communication

The following data applies to all variants (unless otherwise stated).

Product properties

Material

Detailed information on the materials can be found in chapter [“3.2. Material specifications”](#) on page 17.

Non wetted parts

Blind cover	Stainless steel 304/1.4301
Transmitter housing	Stainless steel 304/1.4301
Functional earth element	Cylinder screw, washer, washer spring in stainless steel A4 and blind rivet nut in stainless steel 1.4578/A4
Pressure compensating element	Diaphragm in ePTFE (expanded polytetrafluoroethylene), O-ring in silicone 60 Shore A, body in stainless steel
Display module	Float glass, stainless steel 304/1.4301 and EPDM (ethylene propylene diene monomer) seal
Seal	VMQ silicone (Methyl Vinyl Silicone)
M12 fixed connector and screwed plug	<ul style="list-style-type: none"> • 4-pin M12 circular female connector: <ul style="list-style-type: none"> – Body in stainless steel 304L/1.4307, contact support in PBT GF30 (Polybutyleneterephthalate 30 % glass fibre reinforced) and seal in EPDM • 5-pin M12 circular male connector: <ul style="list-style-type: none"> – Body in nickel plated brass and seal in NBR (nitrile butadiene rubber) or – Body in stainless steel 316L/1.4404 and seal in NBR or VMQ silicone
Cable gland	<ul style="list-style-type: none"> • Body in nickel plated brass and seal in TPE (thermoplastic elastomer) or • Body in stainless steel 304L/1.4307 and seal in TPE (FDA-compliant) or • Body in stainless steel 316L/1.4404 and seal in EPDM
Blind plug	Black POM (polyoxymethylene), PA6 or PA
Display	<ul style="list-style-type: none"> • 2.4", monochrome graphic (240 × 160 pixels) • Languages: German, English, French

Weight (approx. in kg)	DN 08, 3/8", 1/2"	DN 15, 3/4"	DN 25, 1"	DN 40, 1 1/2"	DN 50, 2"	DN 65, 2 1/2"	DN 80, 3"
Clamp	2.1	2	2.2	3	3.2	5.4	5.5
Flange	2.3	2.4	2.7	3.6	3.8	6	6.2
Thread (dairy thread)	–	–	–	–	–	5.7	6.1

Performance data

Frequency resolution	0.05 Hz over 0...2 000 Hz range
4...20 mA output uncertainty	±0.04 mA
4...20 mA output resolution	0.8 µA

Electrical data

Power consumption	Without any consumption of output <ul style="list-style-type: none"> • For device with 2 x M20 x 1.5 cable glands and 1 x 5-pin M12 circular male connector: max. 5 W • For device with 2 x 4-pin M12 circular female connectors and 1 x 5-pin M12 male connector, Ethernet variant: max. 8 W • For device with 2 x 4-pin M12 circular female connectors and 1 x 5-pin M12 male connector, Ethernet variant, with display module: max. 9 W
-------------------	-----------------------------------------------------------------------------------------------------------------------------------------------------------------------------------------------------------------------------------------------------------------------------------------------------------------------------------------------------------------------------------------------------------------------------------------------------------------------------

Output

Number of outputs	3 (1 digital, 1 analogue and 1 configurable: digital or analogue)
Digital output	<p>Overload information (through software diagnostics function)</p> <p>Transistor:</p> <ul style="list-style-type: none"> • Type: NPN or PNP (wiring dependent), open collector, galvanically isolated • Operating modes: pulse (by default), On/Off, threshold, frequency (user configurable) • 10 kHz, 5...35 V DC, max. 700 mA, max. pulse duration: 2 s, selectable limits: <ul style="list-style-type: none"> – 0.0001...10 000 pulses/litre or 0.0001...9 999.99 litres/pulse – 0.0001...10 000 pulses/kg or 0.0001...9 999.99 kg/pulse^{1.)} • Protected against polarity reversals of DC and overloads
Analogue output	<p>Open loop detection (through software diagnostics function)</p> <p>Current:</p> <ul style="list-style-type: none"> • 4...20 mA • 3.6 mA or 22 mA to indicate an error (only if 4...20 mA scale selected); galvanically isolated • Max. loop impedance: 1 300 Ω at 35 V DC, 1 000 Ω at 30 V DC, 700 Ω at 24 V DC, 450 Ω at 18 V DC

Process/Pipe connection & communication

Electrical connection	2 x M20 x 1.5 cable glands and 1 x 5-pin M12 circular male connector (A-coded) for non-Ethernet variants only
Data transfer	External communication through büS (Bürkert system bus, CANopen protocol)

Environment and installation**Ambient temperature**

Operation	<ul style="list-style-type: none"> • For device with 2 x M20 x 1.5 cable glands and 1 x 5-pin M12 circular male connector: <ul style="list-style-type: none"> – -10...+70 °C (+14...+158 °F) or -10...+40 °C (+14...+104 °F) for ATEX/IECEx variant, if -20 °C (4 °F) ≤ fluid temperature ≤ 80 °C (176 °F), – At a fluid temperature > 80 °C (176 °F), the maximum ambient temperature decreases linearly from 70 °C (158 °F) up to 40 °C (104 °F) or from 40 °C (104 °F) up to 30 °C (86 °F) for ATEX/IECEx variant. This means that at a fluid temperature of 80 °C (176 °F) the ambient temperature may be a maximum of 70 °C and at a fluid temperature of 140 °C (130 °C for the ATEX/IECEx variant) the ambient temperature may only be a maximum of 40 °C (30 °C for the ATEX/IECEx variant). • For device with 2 x 4-pin M12 circular female connectors and 1 x 5-pin M12 circular male connector, Ethernet variant: -10...+55 °C (+14...+131 °F) <p>Detailed information can be found in chapter “5.1. Medium temperature diagram” on page 25.</p>
-----------	----------------------------------------------------------------------------------------------------------------------------------------------------------------------------------------------------------------------------------------------------------------------------------------------------------------------------------------------------------------------------------------------------------------------------------------------------------------------------------------------------------------------------------------------------------------------------------------------------------------------------------------------------------------------------------------------------------------------------------------------------------------------------------------------------------------------------------------------------------------------------------------------------------------------------------------------------------------------------------------------------------------------------------------------------------------------------------------------------------------------------

1.) Only if option density and mass flow is activated.

With industrial communication (Ethernet variant)**Process/Pipe connection & communication**

Electrical connection	2 × 4-pin M12 circular female connectors (D-coded) and 1 × 5-pin M12 male connector (A-coded)
-----------------------	-----------------------------------------------------------------------------------------------

Industrial Communication

Supported network protocol	<ul style="list-style-type: none"> • Modbus TCP • PROFINET • EtherNet/IP • EtherCAT
Light-emitting diode	<ul style="list-style-type: none"> • 2 Link/Act LEDs (green) • 2 Link LEDs (yellow)

Modbus TCP protocol

Protocol	Internet protocol, version 4 (IPv4)
Network topology	<ul style="list-style-type: none"> • Tree • Star • Line (open daisy chain)
IP configuration	<ul style="list-style-type: none"> • Static IP address • Not supported: BOOTP (Bootstrap Protocol), DHCP (Dynamic Host Configuration)
Transmission speed	10 or 100 MBit/s

PROFINET protocol

PROFINET IO specification	V2.3
Network topology	<ul style="list-style-type: none"> • Tree • Star • Ring (closed daisy chain) • Line (open daisy chain)
Network management	<ul style="list-style-type: none"> • LLDP (Link Layer Discovery Protocol) • SNMP V1 (Simple Network Management Protocol) • MIB (Management Information Base)
IP configuration	<ul style="list-style-type: none"> • DCP (Discovery and Configuration Protocol) • Manual (Device naming and IP setting)
Transmission speed	100 MBit/s full duplex
Maximum supported conformance class	CC-B
Media Redundancy (for ring topology)	MRP client is supported
GSDml file	See Device Description Files Type 8098 ▶ on the website in the Software chapter.

EtherNet/IP protocol

Protocol	Internet protocol, version 4 (IPv4)
Network topology	<ul style="list-style-type: none"> • Tree • Star • Ring (closed daisy chain) • Line (open daisy chain) • Linear (open Daisy Chain)
IP configuration	<ul style="list-style-type: none"> • Static IP address • BOOTP (Bootstrap Protocol) • DHCP (Dynamic Host Configuration Protocol)
Transmission speed	10 or 100 MBit/s
Duplex mode	Half duplex, full duplex, auto-negotiation
MDI mode (Medium Dependant Interface)	Auto-MDIX
Predefined standard objects	Identity, Message Router, Assembly, Connection Manager, DLR, QoS, TCP/IP Interface, EtherNet Link object
EDS file	See Device Description Files Type 8098 ▶ on the website in the Software chapter.

EtherCAT protocol^{1.)}

Industrial Ethernet interface X1, X2	X1: EtherCAT IN, X2: EtherCAT OUT
Maximum number of cyclic input/output data	512 bytes in total
Maximum number of cyclic input data	1024 bytes
Maximum number of cyclic output data	1024 bytes
Acyclic communication (CoE)	<ul style="list-style-type: none"> • SDO • SDO master-slave • SDO slave-slave (depends on master capacity)
Type	Complex slave
Fieldbus Memory Management Unit (FMMU)	8
Sync Manager	4
Transmission speed	100 Mbit/s

Approvals and Certificates

Certification	<ul style="list-style-type: none"> • PROFINET • EtherNet/IP
---------------	-------------------------------------------------------------------------------------

1.) EtherCAT® is a registered trademark and patented technology, licensed by Beckhoff Automation GmbH.

1.4. FLOWave S flowmeter

The FLOWave S flowmeter is available in four variants of the transmitter:

- Stainless steel transmitter without output and with stainless steel 5-pin M12 circular male connector
- Stainless steel transmitter with 2 configurable outputs (DO/AO) and stainless steel 8-pin M12 circular male connector
- Stainless steel transmitter without output and with stainless steel 5-pin M12 circular male connector (ATEX/IECEX variant)
- Stainless steel transmitter with 2 configurable outputs (DO/AO) and stainless steel 8-pin M12 circular male connector (ATEX/IECEX variant)



Product properties

Material

Detailed information on the materials can be found in chapter "3.2. Material specifications" on page 17.

Non wetted parts

Cover	Stainless steel 304/1.4301
Light guide	PC (Polycarbonate) and O-ring in EPDM (Ethylene Propylene Diene Monomer)
Transmitter housing	Stainless steel 304/1.4301
Seal	Between sensor and transmitter: VMQ silicone (Methyl Vinyl Silicone)
M12 fixed connector and screwed plug	5- or 8-pin M12 circular male connector: stainless steel 316L/1.4404 or 303/1.4305 and with seal in EPDM

Weight (approx. in kg)	DN 08, 3/8", 1/2"	DN 15, 3/4"	DN 25, 1"	DN 40, 1 1/2"	DN 50, 2"	DN 65, 2 1/2"	DN 80, 3"
Clamp	1.7	1.6	1.8	2.6	2.8	5.0	5.1
Flange	1.9	2.0	2.3	3.2	3.4	5.6	5.8
Thread (dairy thread)	–	–	–	–	–	5.3	5.7

Electrical data

Power consumption	<ul style="list-style-type: none"> • For device without output: max. 2.5 W • For device with 2 outputs (DO/AO): max. 5 W
-------------------	--------------------------------------------------------------------------------------------------------------------------------------------------

Output

Number of outputs	Only for device with 8-pin M12 circular male connector 2, each configurable as digital or analogue output
Digital output	Overload information (through software diagnostics function) Transistor: <ul style="list-style-type: none"> • Type: NPN or PNP (wiring dependent), open collector, galvanically isolated • Operating modes: pulse (by default), On/Off, threshold, frequency (user configurable) • 10 kHz, 5...35 V DC, max. 700 mA, max. pulse duration: 2 s, selectable limits: <ul style="list-style-type: none"> – 0.0001...10 000 pulses/litre or 0.0001...9 999.99 litres/pulse – 0.0001...10 000 pulses/kg or 0.0001...9 999.99 kg/pulse¹⁾ • Protected against polarity reversals of DC and overloads
Analogue output	Open loop detection (through software diagnostics function) Current: <ul style="list-style-type: none"> • 4...20 mA • 3.6 mA or 22 mA to indicate an error (only if 4...20 mA scale selected); galvanically isolated • Max. loop impedance: 1300 Ω at 35 V DC, 1000 Ω at 30 V DC, 700 Ω at 24 V DC, 450 Ω at 18 V DC

Process/Pipe connection & communication

Electrical connection	<ul style="list-style-type: none"> • 1 × 5-pin M12 circular male connector (A-coded) for device without output • 1 × 8-pin M12 circular male connector (A-coded) for device with 2 outputs
-----------------------	--------------------------------------------------------------------------------------------------------------------------------------------------------------------------------------------------------------------

Data transfer

- Device without output: external communication through bÜS (Bürkert system bus, CANopen protocol)
- Device with 2 outputs: bÜS connection only to the Bürkert Communicator for configuration and software update of the device. Due to the missing CAN shield the conventional bÜS/CANopen communication is not recommended.

Environment and installation

Ambient temperature

Operation

- -10...+70 °C (+14...+158 °F) if -20 °C (4 °F) ≤ fluid temperature ≤ 80 °C (176 °F) or for ATEX/IECEX variant, -10...+60 °C (+14...+140 °F) if -20 °C (4 °F) ≤ fluid temperature ≤ 100 °C (212 °F)
- At a fluid temperature >80 °C (176 °F), the maximum ambient temperature decreases linearly from 70 °C (158 °F) up to 40 °C (104 °F).
This means that at a fluid temperature of 80 °C (176 °F) the ambient temperature may be a maximum of 70 °C (158 °F) and at a fluid temperature of 140 °C (284 °F) the ambient temperature may only be a maximum of 40 °C (104 °F).
or for ATEX/IECEX variant, at a fluid temperature >100 °C (212 °F), the maximum ambient temperature decreases linearly from 60 °C (140 °F) up to 45 °C (136 °F).
This means that at a fluid temperature of 100 °C (212 °F) the ambient temperature may be a maximum of 60 °C (140 °F) and at a fluid temperature of 130 °C (266 °F) the ambient temperature may only be a maximum of 45 °C (136 °F)

Detailed information can be found in chapter **“5.1. Medium temperature diagram”** on page [25](#).

1.) Only if option density measurement and mass flow rate measurement is activated

2. Approvals

2.1. Certifications

Note:

- The certification listed below must be stated when making enquiries. This is the only way to ensure that the product complies with all required specifications.
- Not all available variant of the devices can be supplied with the certification below.

Certification	Description				
	<p>EHEDG (Type EL - CLASS I) The EHEDG compliance is only valid</p> <ul style="list-style-type: none"> • if the flowmeter with clamp connection according to DIN 32676 is used in combination with gaskets from Combifit International B.V. • if the flowmeter with threaded connection according to DIN 11851 is used in combination with gaskets from <ul style="list-style-type: none"> – Kieselmann GmbH, Germany (ASEPTO-STAR k-flex upgrade gaskets) or – Siersema Componenten Service (S.K.S.) B.V. (Netherlands SKS gasket set DIN 11851 EHEDG with EPDM or FKM inner gasket) 				
	<p>3-A Sanitary Standards The Type 8098 meets sanitary standards for design and fabrication. Certificate authorization number: 1178</p>				
	<p>UL-Listed for USA and Canada The products are UL-listed and also comply with the following standards:</p> <ul style="list-style-type: none"> • UL 61010-1 • CAN/CSA-C22.2 No.61010-1 <p>Certificate number: 2017-10-27-E237737</p>				
 	<p>Explosion proof As Category 3 device suitable for zone 2/22 (optional)</p> <table border="1"> <thead> <tr> <th>FLOWave L flowmeter</th> <th>FLOWave S flowmeter</th> </tr> </thead> <tbody> <tr> <td> <p>ATEX</p> <ul style="list-style-type: none"> • II 3G Ex ec IIC T4 Gc • II 3D Ex tc IIIC T110 °C Dc or T130 °C Dc <p>IECEX</p> <ul style="list-style-type: none"> • Ex ec IIC T4 Gc • Ex tc IIIC T110 °C Dc or T130 °C Dc </td> <td> <p>ATEX</p> <ul style="list-style-type: none"> • II 3G Ex ec IIC T4 Gc • II 3D Ex tc IIIC T130 °C Dc <p>IECEX</p> <ul style="list-style-type: none"> • Ex ec IIC T4 Gc • Ex tc IIIC T130 °C Dc </td> </tr> </tbody> </table> <p>Measures to comply with ATEX/IECEX requirements: refer to the</p> <ul style="list-style-type: none"> • Supplement Type 8098 FLOWave L ATEX/IECEX Variant ▶ or • Supplement Type 8098 FLOWave S ATEX/IECEX Variant ▶ <p>under user manual. The Ex. certification is only valid if the Bürkert device is used as described in the supplement ATEX/IECEX. If unauthorized changes are made to the device, the Ex. certification becomes invalid.</p>	FLOWave L flowmeter	FLOWave S flowmeter	<p>ATEX</p> <ul style="list-style-type: none"> • II 3G Ex ec IIC T4 Gc • II 3D Ex tc IIIC T110 °C Dc or T130 °C Dc <p>IECEX</p> <ul style="list-style-type: none"> • Ex ec IIC T4 Gc • Ex tc IIIC T110 °C Dc or T130 °C Dc 	<p>ATEX</p> <ul style="list-style-type: none"> • II 3G Ex ec IIC T4 Gc • II 3D Ex tc IIIC T130 °C Dc <p>IECEX</p> <ul style="list-style-type: none"> • Ex ec IIC T4 Gc • Ex tc IIIC T130 °C Dc
FLOWave L flowmeter	FLOWave S flowmeter				
<p>ATEX</p> <ul style="list-style-type: none"> • II 3G Ex ec IIC T4 Gc • II 3D Ex tc IIIC T110 °C Dc or T130 °C Dc <p>IECEX</p> <ul style="list-style-type: none"> • Ex ec IIC T4 Gc • Ex tc IIIC T110 °C Dc or T130 °C Dc 	<p>ATEX</p> <ul style="list-style-type: none"> • II 3G Ex ec IIC T4 Gc • II 3D Ex tc IIIC T130 °C Dc <p>IECEX</p> <ul style="list-style-type: none"> • Ex ec IIC T4 Gc • Ex tc IIIC T130 °C Dc 				
	<p>PROFINET Certificate number: Z12446</p>				
	<p>EtherNet/IP Document number: 11839</p>				

DTS 1000270652 EN Version: T Status: RL (released | freigegeben | valide) printed: 16.01.2023

2.2. Certificates

Note:

- The certificate listed below must be stated when making enquiries. This is the only way to ensure that the product complies with all required specifications.
- Not all available variant of the devices can be supplied with the certificate below.

Certificate	Description
FDA	Food contact The devices comply in their composition with the Code of Federal Regulations published by the FDA (Food and Drug Administration, USA).
 EtherCAT®	EtherCAT® is a registered trademark and patented technology, licensed by Beckhoff Automation GmbH

2.3. Pressure equipment directive

The device conforms to article 4, paragraph 1 of the pressure equipment directive 2014/68/EU under the following conditions:

Device used on a pipe

Note:

- The data in the table is independent of the chemical compatibility of the material and the fluid.
- PS = maximum admissible pressure (in bar), DN = nominal diameter of the pipe

Type of fluid	Conditions
Fluid group 1, article 4, paragraph 1.c.i	DN ≤ 25
Fluid group 2, article 4, paragraph 1.c.i	DN ≤ 32 or PS*DN ≤ 1000
Fluid group 1, article 4, paragraph 1.c.ii	DN ≤ 25 or PS*DN ≤ 2000
Fluid group 2, article 4, paragraph 1.c.ii	DN ≤ 200 or PS ≤ 10 or PS*DN ≤ 5000

3. Materials

3.1. Chemical Resistance Chart – Bürkert resistApp

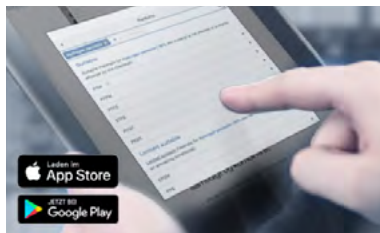

Bürkert resistApp – Chemical Resistance Chart

You want to ensure the reliability and durability of the materials in your individual application case? Verify your combination of media and materials on our website or in our resistApp.

[Start Chemical Resistance Check](#)

3.2. Material specifications

FLOWave L flowmeter without industrial communication

Note:

The following picture describes a device with 2 x M20 x 1.5 cable glands, 1 x 5-pin M12 circular male connector and clamp process connection.

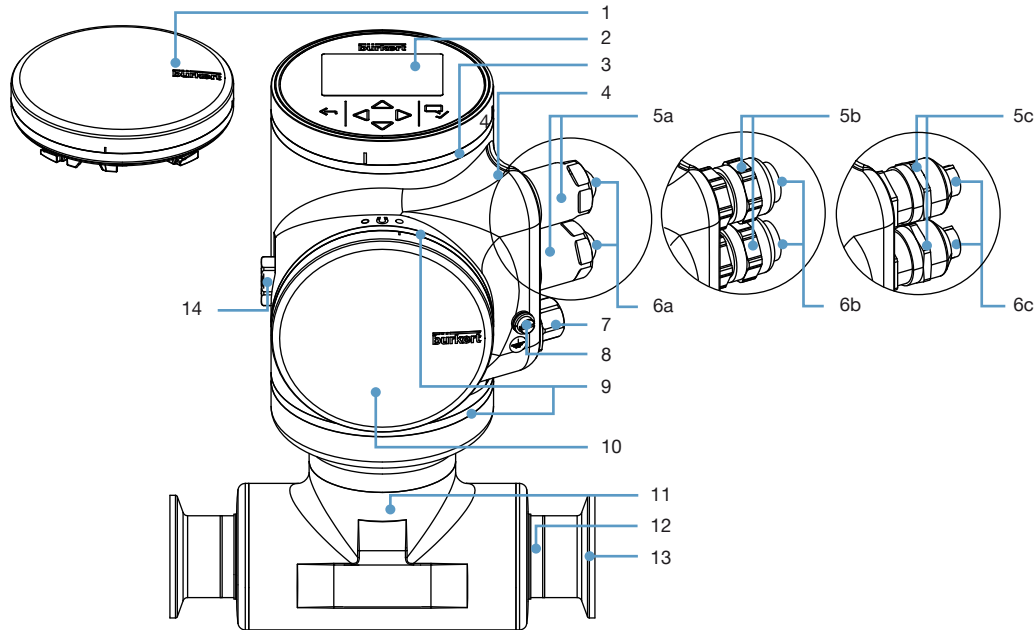

No.	Description	Material
1	Blind cover	Stainless steel 304/1.4301
2	Display module	Float glass, stainless steel 304/1.4301
3	Multi-colour LED behind seal (used for e.g. to indicate the status of the product, based on the NAMUR NE 107 standard)	VMQ silicone
4	Transmitter housing	Stainless steel 304/1.4301
5	Cable gland (full stainless steel variant)	Body in stainless steel 304L/1.4307 and seal in TPE (according to FDA)
6a	Cable glands	Body in nickel plated brass and seal in TPE
6b	Cable glands (ATEX/IECEx variant)	Body in stainless steel 316L/1.4404 and seal in EPDM
6c	Blind plug (full stainless steel variant)	PA6
7a	Blind plug	Black POM
7b	Blind plug (ATEX/IECEx variant)	PA
7c	5-pin M12 circular male connector (wired to büS) with screwed plug	<ul style="list-style-type: none"> Body in stainless steel 316L/1.4404 and seal in NBR (if equipped with 6a) or in VMQ silicone (if equipped with 6c) or Body in nickel plated brass and seal in NBR (if equipped with 6b)
8	Functional earth	Cylinder screw, washer, washer spring in stainless steel A4 and blind rivet nut in stainless steel 1.4578/A4
9	Seal	VMQ silicone
10	Blind cover	Stainless steel 304/1.4301
11	Sensor housing	For sensor with process connection: <ul style="list-style-type: none"> ≤ DN 50/2": stainless steel 304/1.4301 > DN 50/2": stainless steel 316L/1.4435
12	Sensor measurement tube	Stainless steel 316L/1.4435 with low delta ferrite content
13	Process connection (either clamp connections or flange connections)	Stainless steel 316L/1.4435 with low delta ferrite content
14	Pressure compensating element	Diaphragm in ePTFE, O-ring in silicone 60 Shore A and body in stainless steel (316L/1.4404)

FLOWave L flowmeter with industrial communication
Note:

The following picture describes a device (Ethernet variant) with 2 × 4-pin M12 circular female connectors, 1 × 5-pin M12 circular male connector and flange process connection.

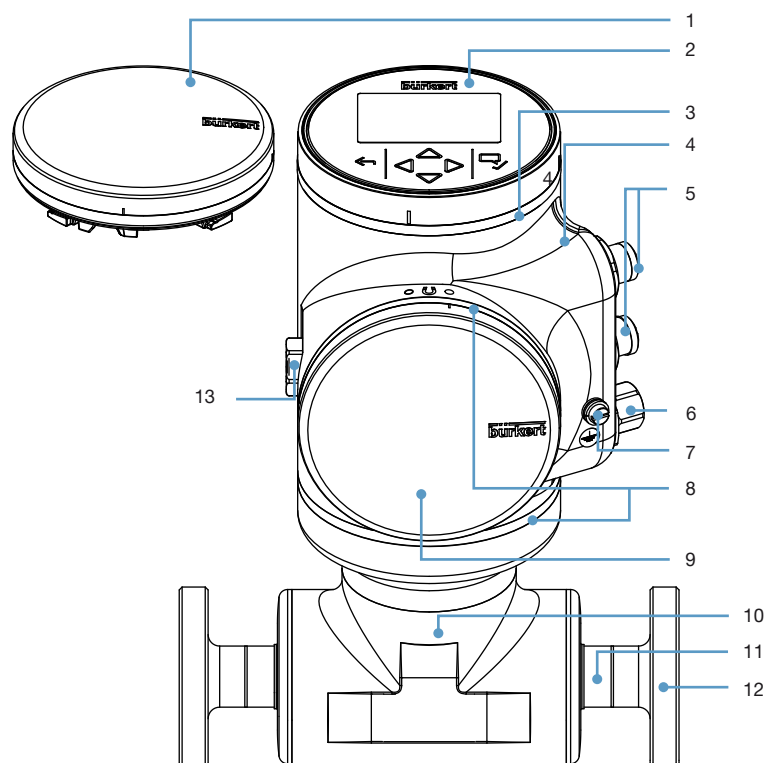

No.	Description	Material
1	Blind cover or	Stainless steel 304/1.4301
2	Display module	Float glass, stainless steel 304/1.4301
3	Multi-colour LED behind seal (used for e.g. to indicate the status of the product, based on the NAMUR NE 107 standard)	VMQ silicone
4	Transmitter housing	Stainless steel 304/1.4301
5	4-pin M12 circular female connectors with screwed plug	Body in stainless steel 304L/1.4307, contact support in PBT GF30 and seal in EPDM
6	5-pin M12 circular male connector (wired to bÜS) with screwed plug	Body in stainless steel 316L/1.4404 and seal in NBR
7	Functional earth	Cylinder screw, washer, washer spring: stainless steel A4 blind rivet nut: stainless steel 1.4578/A4
8	Blind cover	VMQ silicone
9	Seal	Stainless steel 304/1.4301
10	Sensor housing	Stainless steel 304/1.4301 ^{1.)}
11	Sensor measurement tube	Stainless steel 316L/1.4435 with low delta ferrite content
12	Process connection (either clamp connections or flange connections)	Stainless steel 316L/1.4435 with low delta ferrite content
13	Pressure compensating element	Diaphragm: ePTFE; support: polyester; O-ring: silicone 60 Shore A; body: stainless steel (316L/1.4404)

1.) If instead of flange connections there are clamp connections according to DIN 32676 or threaded connections according to DIN 11851, the material of the sensor housing for DN > 50 is stainless steel 316L/1.4435.

FLOWave S flowmeter**Note:**

The following picture shows a device with 1 × 5-pin M12 circular male connector and clamp process connection.

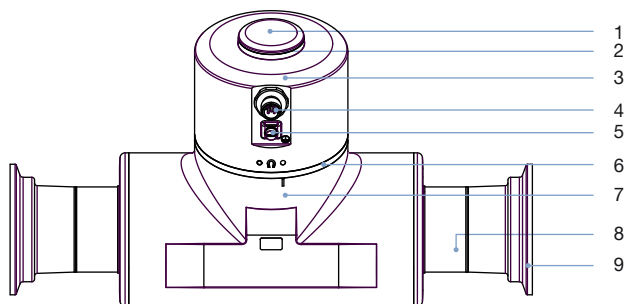

No.	Description	Material
1	Cover	Stainless steel 304/1.4301
2	Light guide for status display behind seal (used for e.g. indicating the status of the product, based on the NAMUR NE 107 standard)	PC and O-ring in EPDM
3	Transmitter housing	Stainless steel 304/1.4301
4	5-pin M12 circular male connector (wired to bÜS) with screwed plug or 8-pin M12 circular male connector (wired to bÜS as service interface ^{1.)} and 2 x DO/AO) (with screwed plug)	Stainless steel 316L/1.4404 or 303/1.4305 and seal in EPDM
5	Functional earth	Cylinder screw, washer, washer spring: stainless steel A4 blind rivet nut: stainless steel 1.4578/A4
6	Seal	VMQ silicone
7	Sensor housing	For sensor with process connection: <ul style="list-style-type: none"> • ≤ DN 50/2": stainless steel 304/1.4301 • > DN 50/2": stainless steel 316L/1.4435
8	Sensor measurement tube	Stainless steel 316L/1.4435 with low delta ferrite content
9	Process connection (either clamp connections or flange connections)	Stainless steel 316L/1.4435 with low delta ferrite content

1.) bÜS connection only to the Bürkert communicator for configuration and software update of the device. Due to the missing CAN shield the conventional bÜS/ CANopen communication is not recommended.

4. Dimensions

4.1. Transmitter of the FLOWave L flowmeter without industrial communication

Note:

Dimensions in mm, unless otherwise stated

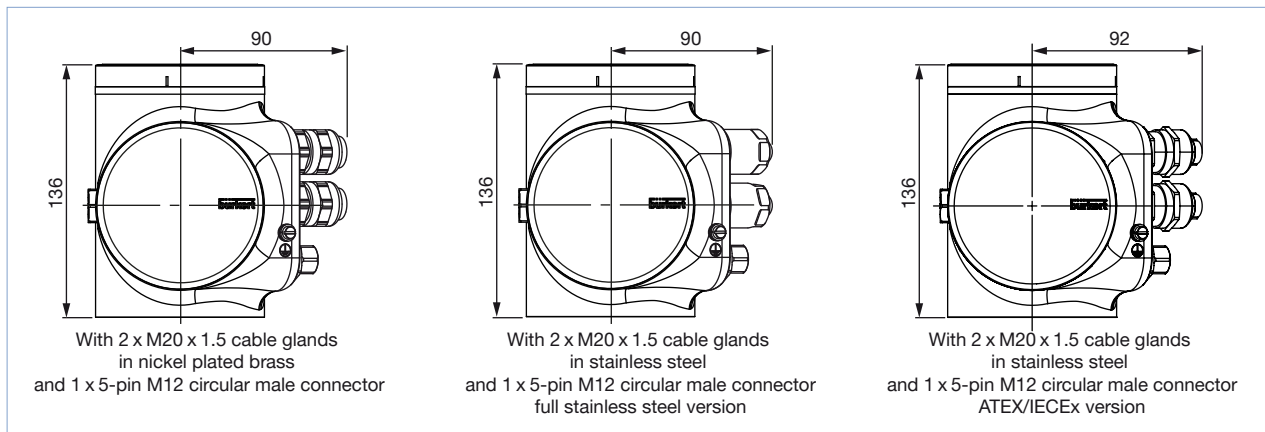

4.2. Transmitter of the FLOWave L flowmeter with industrial communication (Ethernet variant)

Note:

Dimensions in mm, unless otherwise stated

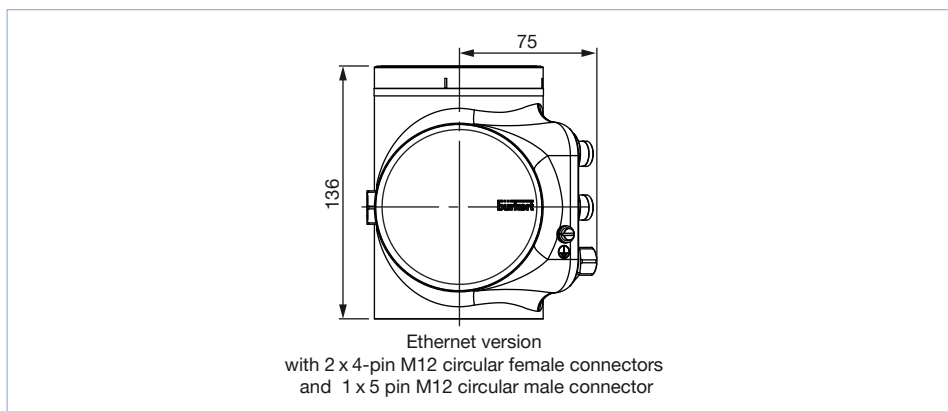

4.3. Transmitter of the FLOWave S flowmeter

Note:

Dimensions in mm, unless otherwise stated

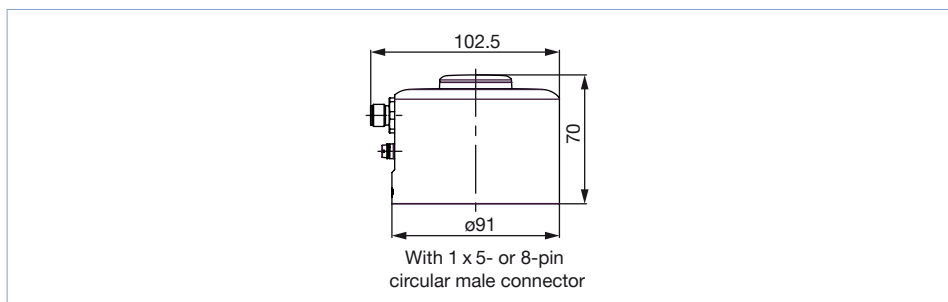

4.4. Flowmeter with clamp process connection

Note:

- Dimensions in mm, unless otherwise stated
- Clamp according to DIN 32676 series A, B or C, or SMS 3017

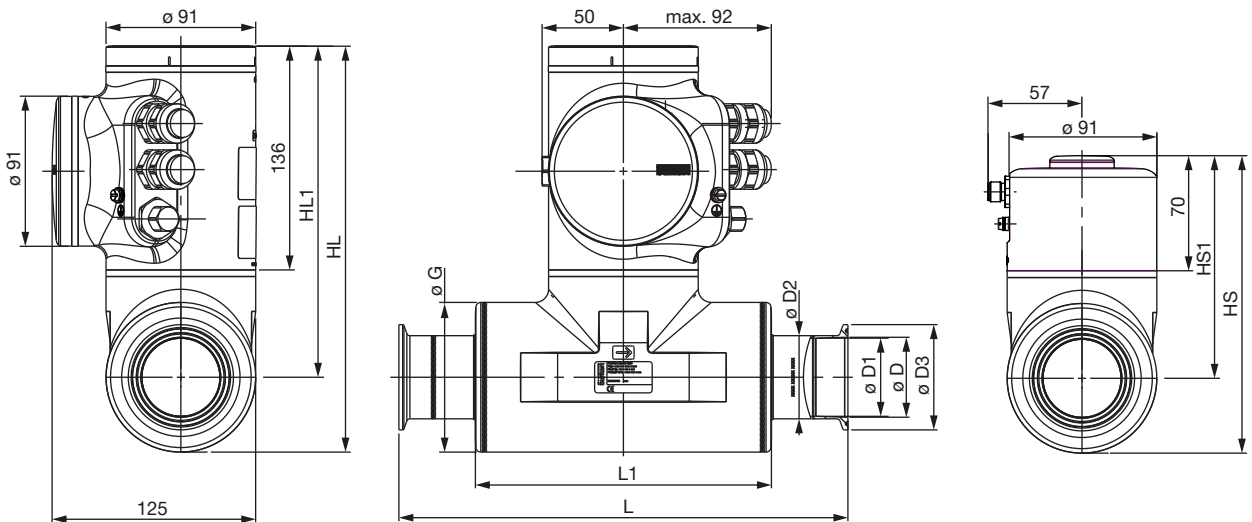
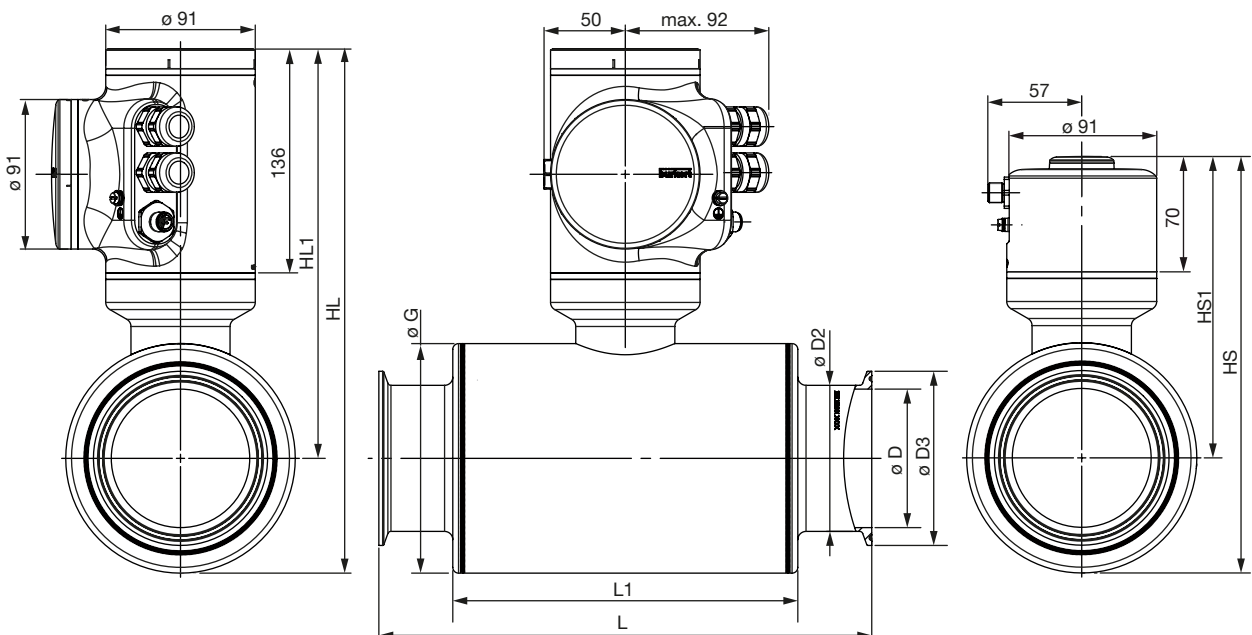
Sensor with process connection \leq DN 50/2"Sensor with process connection $>$ DN 50/2"

Clamp/pipe size												
[mm]	[inch]	HL	HL1	HS	HS1	D1	D	D2	D3	G	L1	L
Clamp according to DIN 32676 series A and process pipe according to DIN 11866 series A (DIN 11850)												
08	–	250	220	184	154	10	10	14	34	60.3	105	158
15 ^{1.)}	–	250	220	184	154	15.75	16	19.05	34	60.3	105	166
25 ^{1.)}	–	250	220	184	154	22.1	26	25.4	50.5	60.3	105	236
40 ^{1.)}	–	250	200	184	134	34.8	38	38.1	50.5	91	180	326
50 ^{1.)}	–	250	200	184	134	47.5	50	50.8	64	91	180	306
65	–	321	251	255	185	66	66	70	91	139.7	210	300
80	–	321	251	255	185	81	81	85	106	139.7	210	300
Clamp according to DIN 32676 series B and process pipe according to DIN 11866 series B (ISO 1127)												
08	–	250	220	184	154	10.3	10.3	14	25	60.3	105	158
15	–	250	220	184	154	18.1	18.1	21.3	50.5	60.3	105	168
15 ^{2.)}	–	250	220	184	154	18.1	18.1	21.3	34	60.3	105	168
25	–	250	220	184	154	29.7	29.7	33.7	50.5	60.3	120	175
40	–	250	200	184	134	44.3	44.3	48.3	64	91	180	273
50	–	250	200	184	134	56.3	56.3	60.3	77.5	91	180	273
65	–	321	251	255	185	72.1	72.1	76.1	91	139.7	210	300
80	–	321	251	255	185	84.3	84.3	88.9	106	139.7	210	300
Clamp according to DIN 32676 series C and process pipe according to DIN 11866 series C (ASME BPE)												
–	¾	250	220	184	154	7.75	7.75	14	25	60.3	105	158
–	½	250	220	184	154	9.4	9.4	14	25	60.3	105	158
–	¾	250	220	184	154	15.75	15.75	19.05	25	60.3	105	143
–	1	250	220	184	154	22.1	22.1	25.4	50.5	60.3	105	143
–	1½	250	200	184	134	34.8	34.8	38.1	50.5	91	180	273
–	2	250	200	184	134	47.5	47.5	50.8	64	91	180	273
–	2½	321	251	255	185	60.2	60.2	63.5	77.5	139.7	210	300
–	3	321	251	255	185	72.9	72.9	76.2	91	139.7	210	300
Clamp according to SMS 3017 and process pipe according to SMS 3008												
25 ^{1.)}	–	250	220	184	154	22.1	22.6	25.4	50.5	60.3	105	143
40 ^{1.)}	–	250	200	184	134	34.8	35.6	38.1	50.5	91	180	273
50 ^{1.)}	–	250	200	184	134	47.5	48.6	50.8	64	91	180	273

1.) DIN 32676 series A and SMS 3017 based on ASME BPE pipe dimension with adapted concentric clamp design
 Design according to EHEDG DOC8 guidelines
 2.) Similar to DIN 32676 series B but with clamp connection 34.0

DTS 1000270652 EN Version: T Status: RL (released | freigegeben | valide) printed: 16.01.2023

4.5. Flowmeter with aseptic collar flange (BF)

Note:

- Dimensions in mm, unless otherwise stated
- Aseptic collar flange (BF) according to DIN 11864-2 form A series A, B or C

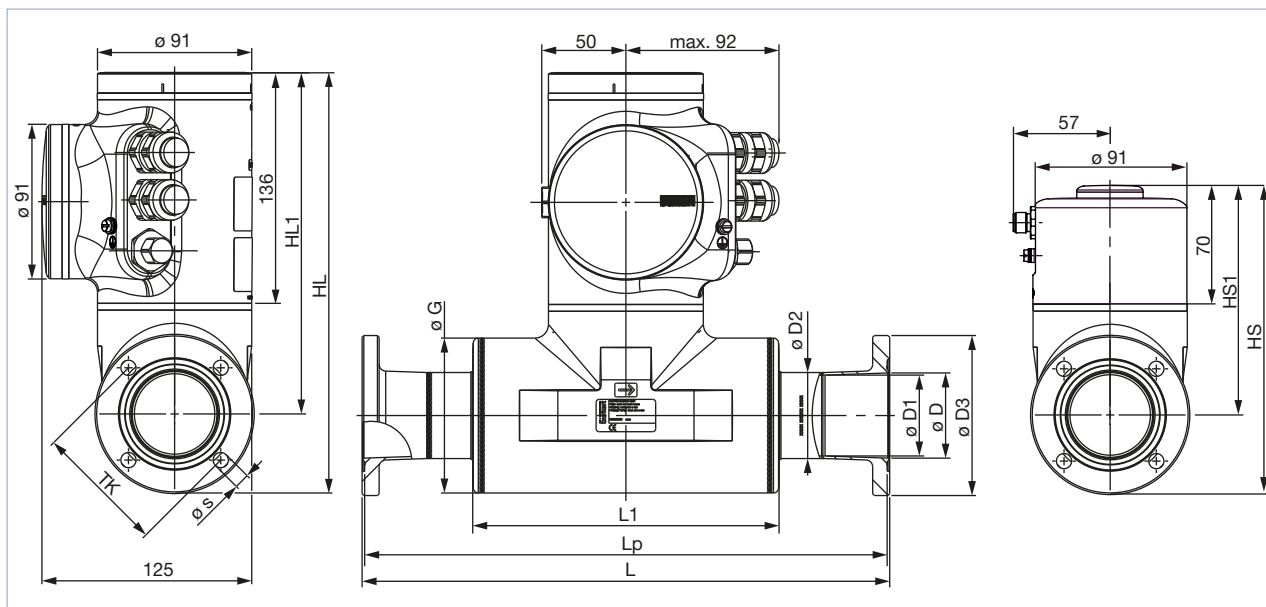

Flange/pipe size															
[mm]	[inch]	HL	HL1	HS	HS1	TK	s	D1	D	D2	D3	G	L1	Lp	L
Flange according to DIN 11864-2 series A and process pipe according to DIN 11866 series A (DIN 11850)															
15 ^{1.)}	-	250	220	184	154	42	9	15.75	16	19.05	59	60.3	105	163	166
25 ^{1.)}	-	250	220	184	154	53	9	22.1	26	25.4	70	60.3	105	237	240
40 ^{1.)}	-	250	200	184	134	65	9	34.8	38	38.1	82	91	180	327	330
50 ^{1.)}	-	250	200	184	134	77	9	47.5	50	50.8	94	91	180	307	310
65	-	321	251	255	185	95	9	66	66	70	113	139.7	210	297	300
80	-	350	265	283	199	112	11	81	81	85	133	168.3	210	297	300
Flange according to DIN 11864-2 series B and process pipe according to DIN 11866 series B (ISO 1127)															
08	-	250	220	184	154	37	9	10.3	10.3	14	54	60.3	105	155	158
15	-	250	220	184	154	45	9	18.1	18.1	21.3	62	60.3	105	170	173
25	-	250	220	184	154	57	9	29.7	29.7	33.7	74	60.3	120	187	190
40	-	250	200	184	134	71	9	44.3	44.3	48.3	88	91	180	275	278
50	-	250	200	184	134	85	9	56.3	56.3	60.3	103	91	180	262	265
65	-	350	265	283	199	104	11	72.1	72.1	76.1	125	168.3	210	29	300
80	-	350	265	283	199	116	11	84.3	84.3	88.9	137	168.3	210	197	300
Flange according to DIN 11864-2 series C and process pipe according to DIN 11866 series C (ASME BPE)															
-	1/2	250	220	184	154	37	9	9.4	9.4	14	54	60.3	105	155	158
-	3/4	250	220	184	154	42	9	15.75	15.75	19.05	59	60.3	105	168	171
-	1	250	220	184	154	49	9	22.1	22.1	25.4	66	60.3	105	165	168
-	1 1/2	250	200	184	134	62	9	34.8	34.8	38.1	79	91	180	275	278
-	2	250	200	184	134	75	9	47.5	47.5	50.8	92	91	180	275	278

1.) DIN 11864-2 series A based on ASME BPE pipe dimension with adapted concentric flange design
Design according to EHEDG DOC8 guidelines

4.6. Flowmeter with aseptic collar clamp (BKS)

Note:

- Dimensions in mm, unless otherwise stated
- Aseptic collar clamp (BKS) according to DIN 11864-3 form A series A, B or C

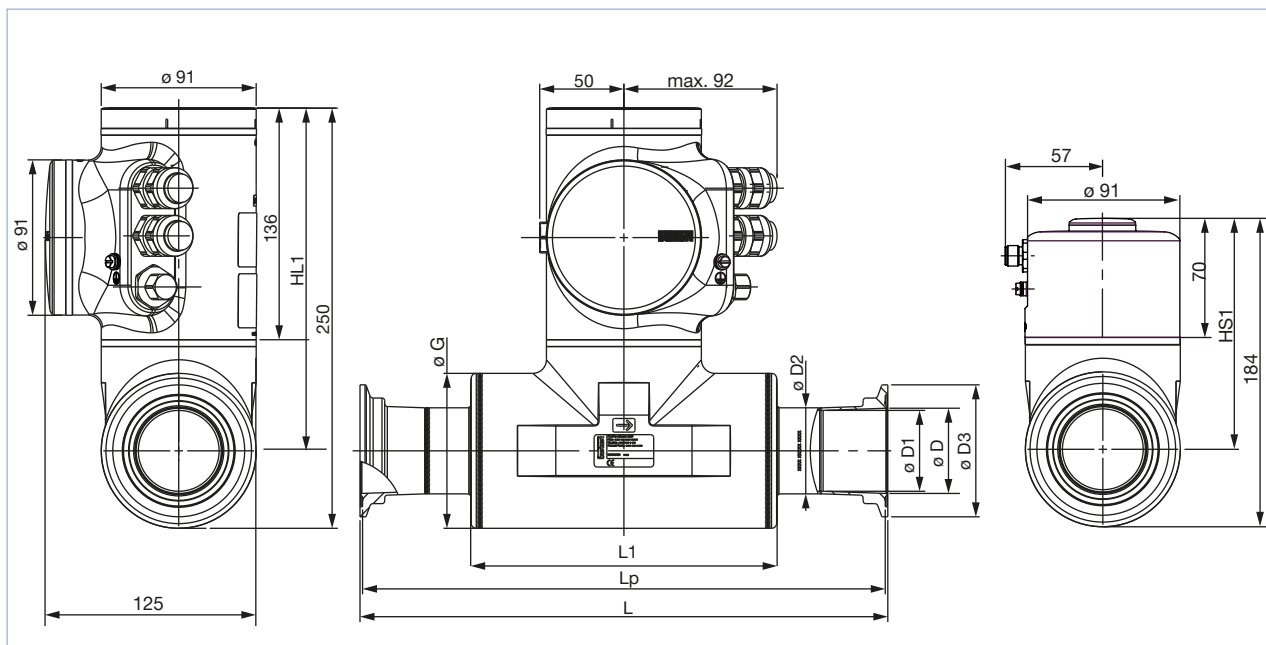

Clamp/pipe size											
[mm]	[inch]	HL1	HS1	D1	D	D2	D3	G	L1	Lp	L
Clamp according to DIN 11864-3 series A and process pipe according to DIN 11866 series A (DIN 11850)											
15 ^{1.)}	-	220	154	15.75	16	19.05	34	60.3	105	163	166
25 ^{1.)}	-	220	154	22.1	26	25.4	50.5	60.3	105	237	240
40 ^{1.)}	-	200	134	34.8	38	38.1	64	91	180	327	330
50 ^{1.)}	-	200	134	47.5	50	50.8	77.5	91	180	307	310
Clamp according to DIN 11864-3 series B and process pipe according to DIN 11866 series B (ISO 1127)											
08	-	220	154	10.3	10.3	14	34	60.3	105	155	158
15	-	220	154	18.1	18.1	21.3	34	60.3	105	166	169
25	-	220	154	29.7	29.7	33.7	50.5	60.3	120	187	190
40	-	200	134	44.3	44.3	48.3	64	91	180	277	280
50	-	200	134	56.3	56.3	60.3	91	91	180	268	271
Clamp according to DIN 11864-3 series C and process pipe according to DIN 11866 series C (ASME BPE)											
-	½	220	154	9.4	9.4	14	34	60.3	105	155	158
-	¾	220	154	15.75	15.75	19.05	34	60.3	105	164	167
-	1	220	154	22.1	22.1	25.4	50.5	60.3	105	161	164
-	1½	200	134	34.8	34.8	38.1	64	91	180	275	278
-	2	200	134	47.5	47.5	50.8	77.5	91	180	276	279

1.) DIN 11864-3 series A based on ASME BPE pipe dimension with adapted concentric clamp design
Design according to EHEDG DOC8 guidelines

4.7. Flowmeter with thread connection

Note:

- Dimensions in mm, unless otherwise stated
- Thread connection according to DIN 11851 series A

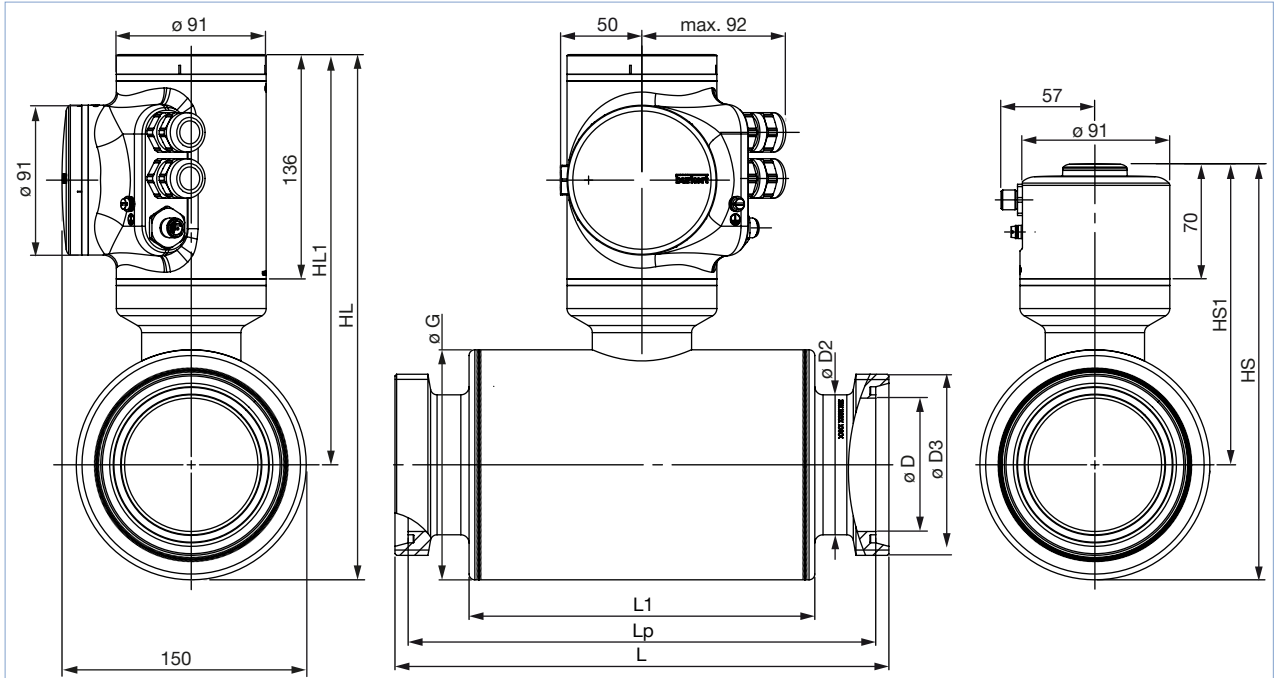

Thread/pipe size												
[mm]	HL	HL1	HS	HS1	D	D2	D3 ^{1.)}	G	L1	Lp	L	
Thread according to DIN 11851												
65	321	251	255	185	66	70	Rd 95 x 1/6	139.7	210	284	300	
80	321	251	255	185	81	85	Rd 110 x 1/4	139.7	210	284	300	

1.) Thread according to DIN 405-1

5. Performance specifications

5.1. Medium temperature diagram

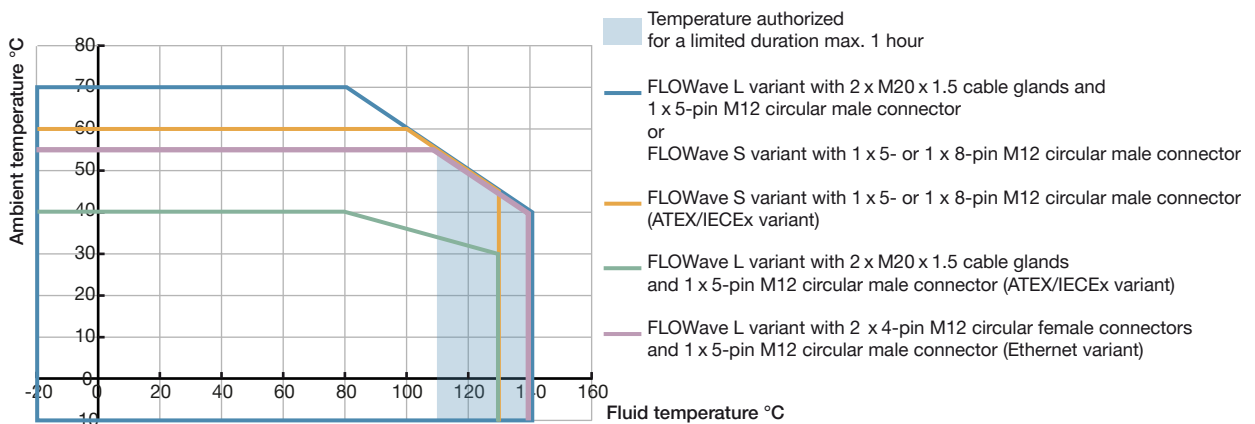

DTS 1000270652 EN Version: T Status: RL (released | freigegeben | valide) printed: 16.01.2023

5.2. Measurement deviation table

Note:

- This table shows the measurement deviations according to the pipe connection standards per measuring range.
- In the following table, the term “full scale” refers to full scale of volume flow rate, i.e. the flow rate corresponding to 10 m/s flow velocity.

DN	Pipe standard	Flow velocity in sensor tube in [m/s] in % of full scale	0.1 1	1 10	10 100
¾"	ASME BPE	Volume flow rate range [m³/h]	0.017 ± 0.08 % of full scale	0.17 ± 0.4 % of measured value	1.7
½"	ASME BPE	Volume flow rate range [m³/h]	0.025 ± 0.08 % of full scale	0.25 ± 0.4 % of measured value	2.5
08	ISO 1127 DIN 11850	Volume flow rate range [m³/h]	0.03 ± 0.08 % of full scale	0.30 ± 0.4 % of measured value	3
¾" 15	ASME BPE DIN 11850	Volume flow rate range [m³/h]	0.07 ± 0.08 % of full scale	0.7 ± 0.4 % of measured value	7
15	ISO 1127	Volume flow rate range [m³/h]	0.10 ± 0.08 % of full scale	1.0 ± 0.4 % of measured value	10
1" 25 25 25	ASME BPE DIN 11850 SMS 3008	Volume flow rate range [m³/h]	0.14 ± 0.08 % of full scale	1.4 ± 0.4 % of measured value	14
25	ISO 1127	Volume flow rate range [m³/h]	0.25 ± 0.08 % of full scale	2.5 ± 0.4 % of measured value	25
1½" 40 40 40	ASME BPE DIN 11850 SMS 3008	Volume flow rate range [m³/h]	0.35 ± 0.08 % of full scale	3.5 ± 0.4 % of measured value	35
40	ISO 1127	Volume flow rate range [m³/h]	0.56 ± 0.08 % of full scale	5.6 ± 0.4 % of measured value	56
2" 50 50 50	ASME BPE DIN 11850 SMS 3008	Volume flow rate range [m³/h]	0.64 ± 0.08 % of full scale	6.4 ± 0.4 % of measured value	64
50	ISO 1127	Volume flow rate range [m³/h]	0.90 ± 0.08 % of full scale	9.0 ± 0.4 % of measured value	90
2½"	ASME BPE	Volume flow rate range [m³/h]	1.02 ± 0.08 % of full scale	10.2 ± 0.4 % of measured value	102
65	DIN 11850	Volume flow rate range [m³/h]	1.23 ± 0.08 % of full scale	12.3 ± 0.4 % of measured value	123
65	ISO 1127	Volume flow rate range [m³/h]	1.47 ± 0.08 % of full scale	14.7 ± 0.4 % of measured value	147
3"	ASME BPE	Volume flow rate range [m³/h]	1.50 ± 0.08 % of full scale	15.0 ± 0.4 % of measured value	150
80	DIN 11850	Volume flow rate range [m³/h]	1.85 ± 0.08 % of full scale	18.5 ± 0.4 % of measured value	185
80	ISO 1127	Volume flow rate range [m³/h]	2.00 ± 0.08 % of full scale	20.0 ± 0.4 % of measured value	200

5.3. Refresh time table

Selectable mode	Volume flow rate	Density	Mass flow rate
Very short	~ 25 ms	1 s	~ 25 ms
Short	~ 40 ms	1 s	~ 40 ms
Long	~ 75 ms	0.5 s	~ 75 ms

6. Product installation

6.1. Installation notes

Note:

The device is not suitable for use in gaseous media and steam. However, their flow does not have any negative effect on the device or its operation. Other liquids flowing through again afterwards are measured correctly as before.

The factory calibration of the FLOWave is done under reference conditions with inlet (40xDN) and outlet (1xDN) distances and the appropriate internal diameter of the pipes.

Deviation from reference conditions can be easily adjusted through the use of a built-in K factor adjustment or Teach in procedure. We can support you if necessary, please do not hesitate to contact us.

The device can be installed into either horizontal, oblique or vertical pipes. But an installation on a vertical pipe will be better to prevent air or gas bubbles inside the measurement area. **For proper operation always ensure a totally filled measurement tube.**

Conformity to 3A and EHEDG requires an angle of at least 5° (for SMS or series A connections) or 3° (all others available connections) against horizontal to ensure complete draining however this not necessary for proper operation of the FLOWave.

The suitable pipe size can be selected using the diagram for selecting the nominal diameter of the pipe. See chapter "6.2. Selection of the nominal diameter" on page 27.

6.2. Selection of the nominal diameter

The graph is used to determine the DN of the pipe and the flowmeter appropriate to the application, according to the fluid velocity and the flow rate. On the chart, the intersection of flow rate and flow velocity gives the appropriate diameter.

Example 1:

Flowmeter with process connection according to DIN 32676 series B (pipe ISO 1127) or DIN 11864-2 form A series B (pipe ISO 1127)

- Flow: 10 m³/h
 - Optimal flow rate: 1...3 m/s
- Result: Select a pipe size of DN 40 or DN 50

Example 2:

Flowmeter with process connection according to DIN 32676 series A (pipe DIN 11850) or DIN 11864-2 series A (pipe DIN 11850)

- Flow: 10 m³/h
 - Optimal flow rate: 1...3 m/s
- Result: Select a pipe size of DN 40 or DN 50

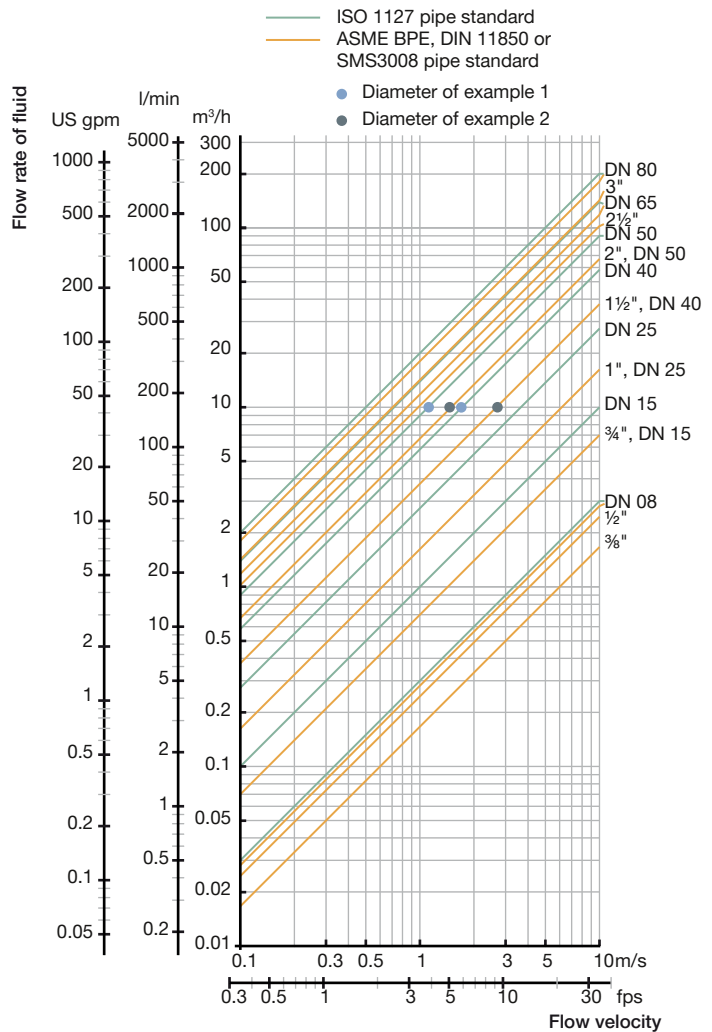

6.3. Mounting options

FLOWave L flowmeter

The product is delivered as described in position 1 in the picture below. The position of the transmitter can be changed in 90° steps. The position of the display module and the blind cover can also be changed in steps of 90° both on the top of the unit and on the front face.

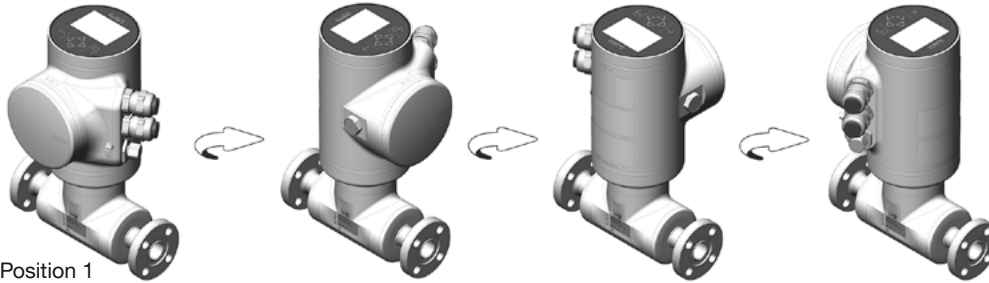

Position 1

For safety reasons the display module and blind cover on the top or front are locked. The display module and blind cover can be unlocked with a magnetic key which is included in the delivery of each device.

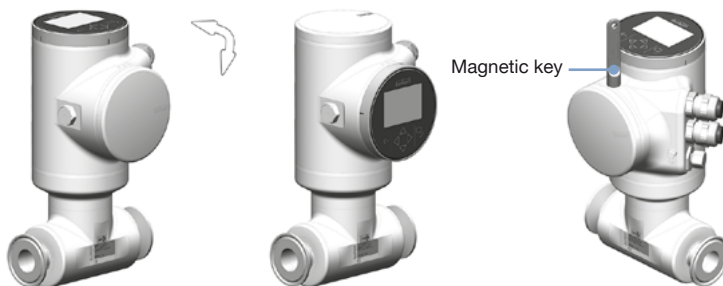

Magnetic key

FLOWave S flowmeter

The product is delivered as described in position 1 in the picture below. The position of the transmitter can be changed in 90° steps. For safety reasons the transmitter is locked. The transmitter can be unlocked with a magnetic key which is included in the delivery of each device.



Position 1

7. Product operation

7.1. Measuring principle

The technology used is based on SAW (Surface Acoustic Waves). The type of wave propagation is similar to what happens when an earthquake occurs in nature.

In the case of FLOWave it is a miniaturized signal, not running on the surface of the earth but on a measurement tube. FLOWave uses so called interdigital transducers which are placed on flattened areas of the tube surface. Each one acts as emitter as well as receiver. Two of them (nos. 1 and 4) emit forward, in the direction of the liquid flow, the others (nos. 2 and 3) backwards, i.e. in the opposite direction to the direction of flow. The propagation time is measured from emitter to receiver. The difference between the forward and backward propagation time of the waves is proportional to the volume flow rate.

The high performance measurement is achieved by the following aspects:

- Each emitter sends multiple signals that are received on two other receivers
- The results are based on the reception of the signals that pass through the liquid one or more times.
- Several measurements can be performed based on the collected information. Many properties of the liquid can be derived, including the flow velocity, the fluid density, the fraction of the transmitted signal (“acoustic transmission factor”), and the so-called “differentiation factor” (see following), as well as information about the presence of gas bubbles or solid parts.
- Mass flow is calculated from fluid density and volume flow.
- Mass flow and density measurements are an option on standard FLOWave flowmeters, which requires adjustment and calibration during manufacture. It is therefore necessary to specify whether or not the device is to be equipped with these features when ordering the device.

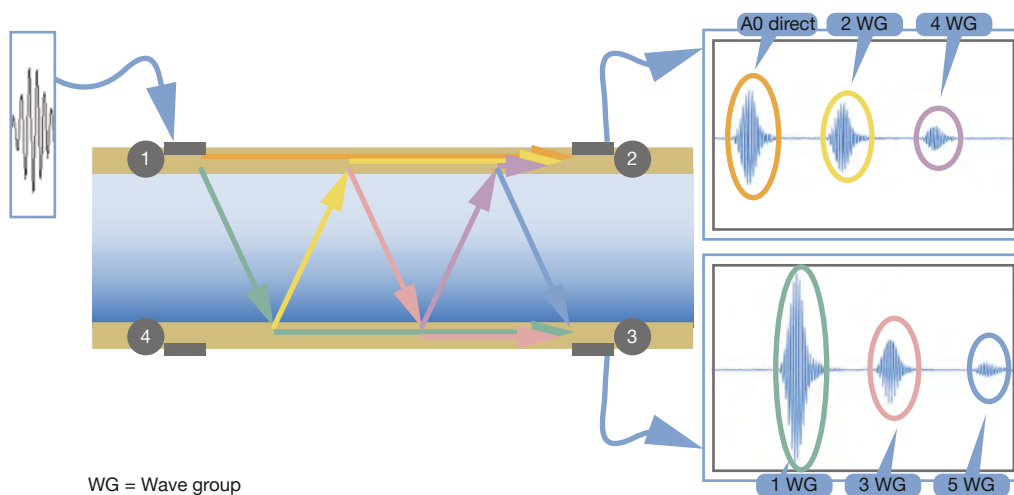

This figure shows, as an example, the reception signals when interdigital transducer 1 is transmitting. The emitter excitation produces the SAW with a frequency of more than 1 MHz.

As a result of the emission of these waves, the following effects occur:

- A wave propagates along the surface of the tube (see orange line).
- A wave is emitted (see green line) and passes through the liquid towards the opposite side of the tube at a certain angle, which depends mainly on the speed of propagation on the surface of the tube and in the liquid.
- Upon reaching the opposite side of the tube, two effects take place.
 - A wave is triggered in the tube and propagates (see green line) to receiver 3
 - A wave is triggered in the liquid (see yellow line) and passes through it again to the opposite wall of the tube. The analysis of the transmitted and received waves allows deriving the process values (velocity, density, flow rates).

These effects are repeated and thus generate the many signals received, which are differentiated in the image with different colours.

7.2. Special functions

Note:

DF, ATF, density and mass flow features must be selected upon initial order of device.

For the detection of gas bubbles and solid particles the device (from firmware version 01.05.00) includes a so called “acoustic transmission factor (ATF)” with a measurement range of 5...120 %, whose value is constantly recorded and directly influenced by the presence of gas bubbles and solid particles.

A “differentiation factor (DF)”, with a measuring range of 0.8...1.3, is available for the detection and differentiation of liquids. This continuously measured value, which uses water as a reference fluid, is temperature-compensated and so its value is representative in a tight value range for each liquid. The changes in value of this process measurement enable differentiation between different liquids.

Before SW version 05.00.00, the differentiation factor was named density factor. As the density option has been added, the name has been changed to avoid confusion.

8. Product design and assembly

8.1. Product assembly

The 8098 flowmeter consists of a S097 flow sensor and a FLOWave L transmitter (variant FLOWave L flowmeter) or FLOWave S transmitter (variant FLOWave S flowmeter).

The flow sensor includes the measurement tube equipped with interdigital transducers, the sensor housing and the process connections in accordance to the standards ISO, ASME BPE, DIN, SMS. At present the sensor size ranges from DN 08 to DN 80 or from 3/8" to 3".

The FLOWave L flowmeter is available with or without display. The high resolution display includes a capacitive working keypad for all interactive user actions, guided by a user friendly menu system. The output signals include one analogue output and one digital output; while a third output signal can be switched between analogue and digital through parametrisation. Electrical connection is done on push-in connectors via two cable glands and/or one M12 circular connector.

The FLOWave S flowmeter is only available without display. The electrical connection is made via an M12 circular male connector.

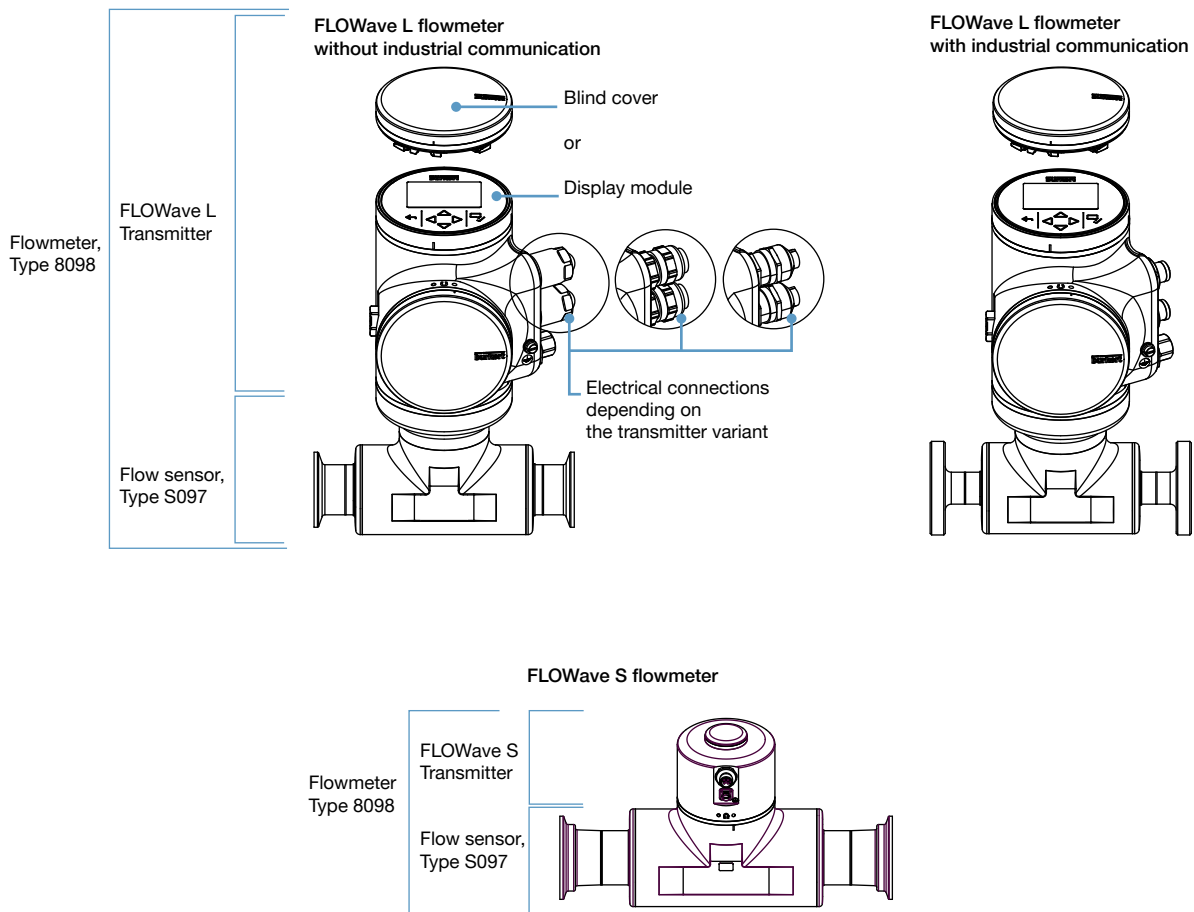

DTS 1000270652 EN Version: T Status: RL (released | freigegeben | valide) printed: 16.01.2023

9. Product accessories

Note:

To set up a device without a display, please use the USB-büS interface, Type 8923, the Bürkert Communicator Type 8920. For the FLOWave S with two outputs, the büS adaptor cable article no. 773286 is required too.

See **Software manual Type 8920** ► for more information.

Accessories	No.	Description
	1	Quick-Start
	2	Power supply: 100...240 V AC/ 24 V DC 1 A and adaptors for power supply worldwide use
	3	büS terminating resistor on büS Y-splitter
	4	5-pin M12 circular male connector wired on free end cable
	5	büS connection cable with 5-pin M12 circular male connector, micro USB B plug
	6	büS adapter with 5-pin M12 circular male connector, A-coded to 5-pin M12 circular male connector, A-coded
	7	büS stick (USB to büS/CANopen adaptor)
	8	büS service cable with 5-pin M12 circular female connector, mini USB and circular plug-in connectors for power supply
	9	Magnetic key
	10	CD - Communicator (30-day license without registration, update and licensing over Bürkert home page)

10. Ordering information

10.1. Bürkert eShop – Easy ordering and quick delivery



Bürkert eShop – Easy ordering and quick delivery

You want to find your desired Bürkert product or spare part quickly and order directly? Our online shop is available for you 24/7. Sign up and enjoy all the benefits.

[Order online now](#)

10.2. Recommendation regarding product selection

Note:

- The installation of the flowmeter in a pipe requires the use of counter-connection, seals, fixing elements, etc. depending on the used norm.
- The drawings show the installation with a FLOWave L variant of the flow meter. The installation is also valid for the FLOWave S variant.

For instance with middle-sized devices:

Connection	Description
	<p>With clamp according to DIN 32676 series A</p> <p>To insert a FLOWave DN 40 with clamps according to DIN 32676 series A (with Ra < 0.8 µm) to a pipe according to DIN 11866 series A (DIN 11850), the correct adapters to be selected and separately ordered are for instance</p> <ul style="list-style-type: none"> • 2x BBS-25 clamp ferrules, article no. 747237, see data sheet Type BBS-25 ► for more information • 2x the appropriate seals (not provided) • 2x the corresponding clamps, article no. 731164

Connection	Description
	<p>With aseptic collar flange (BF) according to DIN 11864-2 form A To insert a FLOWave DN 40 with collar flanges according to DIN 11864-2 series B (with Ra < 0.8 µm) to a pipe according to DIN 11866 series B (ISO 1127), the correct adapters to be selected and separately ordered are for instance</p> <ul style="list-style-type: none"> • 2x BBS-06 aseptic groove flange, article no. 731860, see data sheet Type BBS-06 ▶ for more information • 2x the appropriate seals (not provided) • 8x the corresponding screws, flat washers and nuts (please refer to the DIN 11864-2 standard)
	<p>With aseptic collar clamp (BKS) according to DIN 11864-3 form A To insert a FLOWave 1" with hygienic collar clamps according to DIN 11864-3 series C (with Ra < 0.8 µm) to a pipe according to DIN 11866 series C (ASME BPE), the correct adapters to be selected and separately ordered are for instance</p> <ul style="list-style-type: none"> • 2x BBS-05 aseptic groove clamp, article no. 730272, see data sheet Type BBS-05 ▶ for more information • 2x the appropriate seals (not provided) • 2x the corresponding clamps, article no. 731164
	<p>With thread according to DIN 11851 To insert a FLOWave with thread according to DIN 11851 series A to a pipe according to DIN 11850, suitable adapters (not available from Bürkert) are required, for instance</p> <ul style="list-style-type: none"> • 2x the conical ferrule • 2x the appropriate DIN 11851 seal • 2x the corresponding round slotted nut

10.3. Bürkert product filter

Bürkert product filter – Get quickly to the right product

You want to select products comfortably based on your technical requirements? Use the Bürkert product filter and find suitable articles for your application quickly and easily.

[Try out our product filter](#)

10.4. Bürkert 3D Model - Interactive Animation

Applications & Tools

CAD Model

Interactive Animation

Bürkert 3D Model - Interactive Animation

3D Model and Interactive Animation are available on the website of the flowmeter Type 8098.













See **website of the Type 8098** ▶ under “Applications and Tools”.

10.5. Ordering chart FLOWave L flowmeter with or without industrial communication

Clamp process connection acc. to DIN 32676 series A for pipe acc. to DIN 11866 series A (DIN 11850)

Note:

- To set up a device without a display, please use the USB-büS interface, Type 8923 (has to be ordered separately - see chapter "9. Product accessories" on page 32 and "10.7. Ordering chart accessories" on page 42).
- The following variants are equipped with a display and the special functions ATF (acoustic transmission factor) and DF (differentiation factor).

Clamp and pipe size	Surface quality		Dimensions ^{1.)} D2 x s; D3	Maximal flow rate	Certifications		Article no.
	Housing, outer surface of measurement tube	Inner surface of measurement tube			3A (28-06)	EHEDG ^{2.)}	
[mm]	[µm]	[µm]	[mm]	[m ³ /h]	3A (28-06)	EHEDG ^{2.)}	
Variant without industrial communication (2 cable glands^{3.)} M20 x1.5 + 1 x 5-pin M12 circular male connector), operating voltage of 12...35 V DC							
15	Ra < 1.6	Ra < 0.8	19.05 x 1.65; 34.0	7	Yes	Yes	569159 
		Ra < 0.4					569161 
25		Ra < 0.8	25.4 x 1.65; 50.5	14			569163 
		Ra < 0.4					569165 
40		Ra < 0.8	38.1 x 1.65; 50.5	35			569167 
		Ra < 0.4					569169 
50		Ra < 0.8	50.8 x 1.65; 64.0	64			569171 
		Ra < 0.4					569173 
65		Ra < 0.8	70.0 x 2.0; 91.0	123			573445 
		Ra < 0.4					573373 
80		Ra < 0.8	85.0 x 2.0; 106.0	185			573446 
		Ra < 0.4					573374 

















1.) D2 for holder, s = thickness and D3 for clamp

2.) The EHEDG compliance is only if used in combination with gaskets from Combifit International B.V.

3.) Cable gland in nickel plated brass valid

Clamp process connection acc. to DIN 32676 series B for pipe acc. to DIN 11866 series B (ISO 1127)
Note:

- To set up a device without a display, please use the USB-büS interface, Type 8923 (has to be ordered separately - see chapter “9. Product accessories” on page 32 and “10.7. Ordering chart accessories” on page 42).
- The following variants are equipped with a display and the special functions ATF (acoustic transmission factor) and DF (differentiation factor).

Clamp and pipe size	Surface quality		Dimensions ^{1.)} D2 x s; D3	Maximal flow rate	Certifications		Article no.
	Housing, outer surface of measurement tube	Inner surface of measurement tube			3A (28-06)	EHEDG ^{2.)}	
[mm]	[µm]	[µm]	[mm]	[m ³ /h]	3A (28-06)	EHEDG ^{2.)}	
Variant without industrial communication (2 cable glands^{3.)} M20 x 1.5 + 1 x 5-pin M12 circular male connector), operating voltage of 12...35 V DC							
08	Ra < 1.6	Ra < 0.8	14 x 1.85; 25.0	3	Yes	Yes	573126 
		Ra < 0.4					573128 
15	Ra < 1.6	Ra < 0.8	21.3 x 1.6; 50.5	10	Yes	No	566187 
			21.3 x 1.6; 34.0				566235 
		Ra < 0.4	21.3 x 1.6; 50.5				566195 
			21.3 x 1.6; 34.0				566237 
25	Ra < 1.6	Ra < 0.8	33.7 x 2.0; 50.5	25	Yes	Yes	566188 
		Ra < 0.4					566196 
40	Ra < 1.6	Ra < 0.8	48.3 x 2.0; 64.0	56	Yes	Yes	566189 
		Ra < 0.4					566197 
50	Ra < 1.6	Ra < 0.8	60.3 x 2.0; 77.5	90	Yes	Yes	566190 
		Ra < 0.4					566198 
65	Ra < 1.6	Ra < 0.8	76.1 x 2.0; 91.0	147	Yes	Yes	573442 
		Ra < 0.4					573370 
80	Ra < 1.6	Ra < 0.8	88.9 x 2.3; 106.0	200	Yes	Yes	573443 
		Ra < 0.4					573371 





















1.) D2 for holder; s = thickness; D3: clamp

2.) The EHEDG compliance is only valid if used in combination with gaskets from Combifit International B.V.

3.) Cable gland in nickel plated brass

Clamp process connection acc. to DIN 32676 series C for pipe acc. to DIN 11866 series C (ASME BPE)
Note:

- To set up a device without a display, please use the USB-büS interface, Type 8923 (has to be ordered separately - see chapter “9. Product accessories” on page 32 and “10.7. Ordering chart accessories” on page 42).
- The following variants are equipped with a display and the special functions ATF (acoustic transmission factor) and DF (differentiation factor).

Clamp and pipe size	Surface quality		Dimensions ¹⁾ D2 x s; D3	Maximal flow rate	Certifications			Article no.
	Housing, outer surface of measurement tube	Inner surface of measurement tube			3A (28-06)	EHEDG ²⁾	UL	
[inch]	[µm]	[µm]	[mm]	[m ³ /h]				
Variant without industrial communication (2 cable glands³⁾ M20x1.5+1x5-pin M12 circular male connector), operating voltage of 12...35 V DC								
3/8	Ra<1.6	Ra<0.8	14.00x3.125; 25.0	1.7	Yes	Yes	No	573112 
		Ra<0.4					573114 	
1/2		Ra<0.8	14.00x2.3; 25.0	2.5			Yes	573116 
		Ra<0.4					No	573119 
3/4		Ra<0.8	19.05x1.65; 25.0	7			Yes	573123 
		Ra<0.4					No	566203 
1		Ra<0.8	25.4x1.65; 50.5	14			Yes	566211 
		Ra<0.4					No	566204 
1 1/2		Ra<0.8	38.1x1.65; 50.5	35			Yes	566212 
		Ra<0.4					No	566205 
2		Ra<0.8	50.8x1.65; 64.0	64			Yes	566213 
		Ra<0.4					No	566206 
2 1/2		Ra<0.8	63.5x1.65; 77.5	100			Yes	566214 
		Ra<0.4					No	566207 
3		Ra<0.8	76.2x1.65; 91.0	150			Yes	573448 
		Ra<0.4					No	573376 
							Yes	574710 
							No	573449 
							Yes	573377 
							No	574711 

Clamp and pipe size	Surface quality		Dimensions ^{1.)} D2 x s; D3	Maximal flow rate	Certifications			Article no.
	Housing, outer surface of measurement tube	Inner surface of measurement tube			3A (28-06)	EHEDG ^{2.)}	UL	
[inch]	[µm]	[µm]	[mm]	[m ³ /h]				
Variant with industrial communication (Ethernet variant, 2 x 4-pin M12 circular female connectors + 1 x 5-pin M12 circular male connector), operating voltage of 12...35 V DC								
3/8	Ra < 1.6	Ra < 0.4	14.00 x 3.125; 25.0	1.7	Yes	Yes	No	573117
			Yes	573118				
1/2			14.00 x 2.3; 25.0	2.5			No	573124
			Yes	573125				
3/4			19.05 x 1.65; 25.0	7			No	570444
			Yes	569679				
1			25.4 x 1.65; 50.5	14			No	570445
			Yes	569680				
1 1/2			38.1 x 1.65; 50.5	35			No	570446
			Yes	569681				
2			50.8 x 1.65; 64.0	64			No	570447
			Yes	569682				
2 1/2			63.5 x 1.65; 77.5	100			No	574716
			Yes	574720				
3			76.2 x 1.65; 91.0	150			No	574717
			Yes	574721				

1.) D2 for holder; s = thickness; D3: clamp

2.) The EHEDG compliance is only valid if used in combination with gaskets from Combifit International B.V.

3.) Cable gland in nickel plated brass

Thread process connection acc. to DIN 11851 series A for pipe acc. to DIN 11866 series A (DIN 11850)

Note:

- To set up a device without a display, please use the USB-büS interface, Type 8923 (has to be ordered separately - see chapter “9. Product accessories” on page 32 and “10.7. Ordering chart accessories” on page 42).
- The following variants are equipped with a display and the special functions ATF (acoustic transmission factor) and DF (differentiation factor).

Thread and pipe size	Surface quality		Dimensions ^{1.)} D2 x s; D3	Maximal flow rate	Certifications		Article no.
	Housing, outer surface of measurement tube	Inner surface of measurement tube			3A (28-06)	EHEDG ^{1.)}	
[mm]	[µm]	[µm]	[mm]	[m ³ /h]			
Variant without industrial communication (2 cable glands^{2.)} M20 x 1.5 + 1 x 5-pin M12 circular male connector), operating voltage of 12...35 V DC							
65	Ra < 1.6	Ra < 0.8	70.0 x 2.0; Rd 95 x 1/6	123	Yes	Yes	573463
80		Ra < 0.8	85.0 x 2.0; Rd 110 x 1/4	185			573464

1.) D2 for holder; s = thickness; D3: thread connection





2.) The EHEDG compliance is s only valid if used in combination with EHEDG-compliant gaskets from

1. Kieselmann GmbH, Germany (ASEPTO-STAR k-flex upgrade gaskets) or

2. Siersema Componenten Service (S.K.S.) B.V. (Netherlands SKS gasket set DIN 11851 EHEDG with EPDM or FKM inner gasket)

3.) Cable gland in nickel plated brass

DTS 1000270652 EN Version: T Status: RL (released | freigegeben | valide) printed: 16.01.2023

Further versions on request	
 <p>Process connection</p> <ul style="list-style-type: none"> For pipe DIN 11850: <ul style="list-style-type: none"> Clamp DIN 11864-3 Flange DIN 11864-2 For pipe ISO 1127: <ul style="list-style-type: none"> Clamp DIN 11864-3 Flange DIN 11864-2 For pipe ASME BPE: <ul style="list-style-type: none"> Clamp DIN 11864-3 Flange DIN 11864-2 For pipe SMS 3008: SMS 3017 	<div style="display: flex; justify-content: space-between;"> <div style="width: 45%;">  <p>Additional</p> <ul style="list-style-type: none"> With/without display Without differentiation factor (DF) Without acoustic transmission factor (ATF) With density and mass flow Ethernet module (EtherNet/IP, PROFINET, Modbus TCP/IP, ETHERCAT) ATEX/IECEX </div> <div style="width: 45%;">  <p>Material</p> <ul style="list-style-type: none"> With inner surface of measurement tube <ul style="list-style-type: none"> Ra < 0.8 µm (30 µin.) Ra < 0.4 µm (15 µin.) (electro-polished) according to ISO 4288 </div> </div>
 <p>Orifice</p> <ul style="list-style-type: none"> 08...80 mm ¾...3 inch 	 <p>Electrical connection</p> <p>Cable gland in stainless steel</p>

For any other variants, please use the product enquiry form at the end of this data sheet or check the readily available article no. listed in the Bürkert eShop.

10.6. Ordering chart FLOWave S flowmeter

Clamp process connection acc. to DIN 32676 series A for pipe acc. to DIN 11866 series A (DIN 11850)

Note:

The following variants are equipped with the special functions ATF (acoustic transmission factor) and DF (differentiation factor).

Clamp and pipe size	Surface quality		Dimensions ^{1.)} D2 x s; D3	Maximal flow rate	Certifications		Article no.
	Housing, outer surface of measurement tube	Inner surface of measurement tube			3A (28-06)	EHEDG ^{2.)}	
[mm]	[µm]	[µm]	[mm]	[m ³ /h]			
Electrical connection: 1 x 8-pin M12 circular male connector, operating voltage of 12...35 V DC							
65	Ra < 1.6	Ra < 0.8	70.0x2.0; 91.0	123	Yes	Yes	574689
		Ra < 0.4					573421
80		Ra < 0.8	85.0x2.0; 106.0	185			574690
		Ra < 0.4					573422

1.) D2 for holder; s = thickness; D3: clamp

2.) The EHEDG compliance is only valid if used in combination with gaskets from Combifit International B.V.

DTS 1000270652 EN Version: T Status: RL (released | freigegeben | valide) printed: 16.01.2023

Clamp process connection acc. to DIN 32676 series B for pipe acc. to DIN 11866 series B (ISO 1127)

Note:

The following variants are equipped with the special functions ATF (acoustic transmission factor) and DF (differentiation factor).

Clamp and pipe size	Surface quality		Dimensions ^{1.)} D2 x s; D3	Maximal flow rate	Certifications		Article no.
	Housing, outer surface of measurement tube	Inner surface of measurement tube			3A (28-06)	EHEDG ^{2.)}	
[mm]	[µm]	[µm]	[mm]	[m ³ /h]			
Electrical connection: 1 x 5-pin M12 circular male connector, operating voltage of 12...35 V DC							
08	Ra<1.6	Ra<0.8	14 x 1.85; 25.0	3	Yes	Yes	573716
		Ra<0.4					573717
15	Ra<1.6	Ra<0.8	21.3 x 1.6; 50.5	10	Yes	Yes	573093
						21.3 x 1.6; 34.0	No
		Ra<0.4	21.3 x 1.6; 50.5			Yes	573098
			21.3 x 1.6; 34.0			No	573099
25	Ra<1.6	Ra<0.8	33.7 x 2.0; 50.5	25	Yes	Yes	573095
		Ra<0.4					573100
40	Ra<1.6	Ra<0.8	48.3 x 2.0; 64.0	56	Yes		573096
		Ra<0.4					573101
50	Ra<1.6	Ra<0.8	60.3 x 2.0; 77.5	90	Yes		573097
		Ra<0.4					573102
Electrical connection: 1 x 8-pin M12 circular male connector, operating voltage of 12...35 V DC							
08	Ra<1.6	Ra<0.8	14 x 1.85; 25.0	3	Yes	Yes	571780
		Ra<0.4					571781
15	Ra<1.6	Ra<0.8	21.3 x 1.6; 50.5	10	Yes	Yes	571782
						21.3 x 1.6; 34.0	No
		Ra<0.4	21.3 x 1.6; 50.5			Yes	571784
			21.3 x 1.6; 34.0			No	571785
25	Ra<1.6	Ra<0.8	33.7 x 2.0; 50.5	25	Yes	Yes	571786
		Ra<0.4					571787
40	Ra<1.6	Ra<0.8	48.3 x 2.0; 64.0	56	Yes		571788
		Ra<0.4					571789
50	Ra<1.6	Ra<0.8	60.3 x 2.0; 77.5	90	Yes		571790
		Ra<0.4					571791
65	Ra<1.6	Ra<0.8	76.1 x 2.0; 91.0	147	Yes		574686
		Ra<0.4					573418
80	Ra<1.6	Ra<0.8	88.9 x 2.3; 106.0	200	Yes		574687
		Ra<0.4					573419

1.) D2 for holder; s = thickness; D3: clamp

2.) The EHEDG compliance is only valid if used in combination with gaskets from Combifit International B.V.

DTS 1000270652 EN Version: T Status: RL (released | freigegeben | valide) printed: 16.01.2023

Clamp process connection acc. to DIN 32676 series C for pipe acc. to DIN 11866 series C (ASME BPE)

Note:

The following variants are equipped with the special functions ATF (acoustic transmission factor) and DF (differentiation factor).

Clamp and pipe size	Surface quality		Dimensions ^{1.)} D2 x s; D3	Maximal flow rate	Certifications			Article no.
	Housing, outer surface of measurement tube	Inner surface of measurement tube			3A (28-06)	EHEDG ^{2.)}	UL	
[inch]	[µm]	[µm]	[mm]	[m ³ /h]				
Electrical connection: 1 x 5-pin M12 circular male connector, operating voltage of 12...35 V DC								
3/8	Ra < 1.6	Ra < 0.8	14.00 x 3.125; 25.0	1.7	Yes	Yes	No	573710
		Ra < 0.4					Yes	573711
1/2	Ra < 1.6	Ra < 0.8	14.00 x 2.3; 25.0	2.5	Yes	Yes	No	573712
		Ra < 0.4					Yes	573713
3/4	Ra < 1.6	Ra < 0.8	19.05 x 1.65; 25.0	7	Yes	Yes	No	573714
		Ra < 0.4					Yes	573715
1	Ra < 1.6	Ra < 0.8	25.4 x 1.65; 50.5	14	Yes	Yes	No	573085
		Ra < 0.4					Yes	573086
1 1/2	Ra < 1.6	Ra < 0.8	25.4 x 1.65; 50.5	14	Yes	Yes	No	573087
		Ra < 0.4					Yes	573088
2	Ra < 1.6	Ra < 0.8	38.1 x 1.65; 50.5	35	Yes	Yes	No	573089
		Ra < 0.4					Yes	573090
2	Ra < 1.6	Ra < 0.8	50.8 x 1.65; 64.0	64	Yes	Yes	No	573091
		Ra < 0.4					Yes	573092
2	Ra < 1.6	Ra < 0.8	50.8 x 1.65; 64.0	64	Yes	Yes	No	573190
		Ra < 0.4					Yes	573191
1 1/2	Ra < 1.6	Ra < 0.8	38.1 x 1.65; 50.5	35	Yes	Yes	No	573086
		Ra < 0.4					Yes	573087
2	Ra < 1.6	Ra < 0.8	50.8 x 1.65; 64.0	64	Yes	Yes	No	573088
		Ra < 0.4					Yes	573089
2	Ra < 1.6	Ra < 0.8	50.8 x 1.65; 64.0	64	Yes	Yes	No	573088
		Ra < 0.4					Yes	573092
2	Ra < 1.6	Ra < 0.8	50.8 x 1.65; 64.0	64	Yes	Yes	No	573088
		Ra < 0.4					Yes	573092
2	Ra < 1.6	Ra < 0.8	50.8 x 1.65; 64.0	64	Yes	Yes	No	573088
		Ra < 0.4					Yes	573092
2	Ra < 1.6	Ra < 0.8	50.8 x 1.65; 64.0	64	Yes	Yes	No	573088
		Ra < 0.4					Yes	573092
2	Ra < 1.6	Ra < 0.8	50.8 x 1.65; 64.0	64	Yes	Yes	No	573088
		Ra < 0.4					Yes	573092
2	Ra < 1.6	Ra < 0.8	50.8 x 1.65; 64.0	64	Yes	Yes	No	573088
		Ra < 0.4					Yes	573092
2	Ra < 1.6	Ra < 0.8	50.8 x 1.65; 64.0	64	Yes	Yes	No	573088
		Ra < 0.4					Yes	573092
2	Ra < 1.6	Ra < 0.8	50.8 x 1.65; 64.0	64	Yes	Yes	No	573088
		Ra < 0.4					Yes	573092
2	Ra < 1.6	Ra < 0.8	50.8 x 1.65; 64.0	64	Yes	Yes	No	573088
		Ra < 0.4					Yes	573092
2	Ra < 1.6	Ra < 0.8	50.8 x 1.65; 64.0	64	Yes	Yes	No	573088
		Ra < 0.4					Yes	573092
2	Ra < 1.6	Ra < 0.8	50.8 x 1.65; 64.0	64	Yes	Yes	No	573088
		Ra < 0.4					Yes	573092
2	Ra < 1.6	Ra < 0.8	50.8 x 1.65; 64.0	64	Yes	Yes	No	573088
		Ra < 0.4					Yes	573092
2	Ra < 1.6	Ra < 0.8	50.8 x 1.65; 64.0	64	Yes	Yes	No	573088
		Ra < 0.4					Yes	573092
2	Ra < 1.6	Ra < 0.8	50.8 x 1.65; 64.0	64	Yes	Yes	No	573088
		Ra < 0.4					Yes	573092
2	Ra < 1.6	Ra < 0.8	50.8 x 1.65; 64.0	64	Yes	Yes	No	573088
		Ra < 0.4					Yes	573092
2	Ra < 1.6	Ra < 0.8	50.8 x 1.65; 64.0	64	Yes	Yes	No	573088
		Ra < 0.4					Yes	573092
2	Ra < 1.6	Ra < 0.8	50.8 x 1.65; 64.0	64	Yes	Yes	No	573088
		Ra < 0.4					Yes	573092
2	Ra < 1.6	Ra < 0.8	50.8 x 1.65; 64.0	64	Yes	Yes	No	573088
		Ra < 0.4					Yes	573092
2	Ra < 1.6	Ra < 0.8	50.8 x 1.65; 64.0	64	Yes	Yes	No	573088
		Ra < 0.4					Yes	573092
2	Ra < 1.6	Ra < 0.8	50.8 x 1.65; 64.0	64	Yes	Yes	No	573088
		Ra < 0.4					Yes	573092
2	Ra < 1.6	Ra < 0.8	50.8 x 1.65; 64.0	64	Yes	Yes	No	573088
		Ra < 0.4					Yes	573092
2	Ra < 1.6	Ra < 0.8	50.8 x 1.65; 64.0	64	Yes	Yes	No	573088
		Ra < 0.4					Yes	573092
2	Ra < 1.6	Ra < 0.8	50.8 x 1.65; 64.0	64	Yes	Yes	No	573088
		Ra < 0.4					Yes	573092
2	Ra < 1.6	Ra < 0.8	50.8 x 1.65; 64.0	64	Yes	Yes	No	573088
		Ra < 0.4					Yes	573092
2	Ra < 1.6	Ra < 0.8	50.8 x 1.65; 64.0	64	Yes	Yes	No	573088
		Ra < 0.4					Yes	573092
2	Ra < 1.6	Ra < 0.8	50.8 x 1.65; 64.0	64	Yes	Yes	No	573088
		Ra < 0.4					Yes	573092
2	Ra < 1.6	Ra < 0.8	50.8 x 1.65; 64.0	64	Yes	Yes	No	573088
		Ra < 0.4					Yes	573092
2	Ra < 1.6	Ra < 0.8	50.8 x 1.65; 64.0	64	Yes	Yes	No	573088
		Ra < 0.4					Yes	573092
2	Ra < 1.6	Ra < 0.8	50.8 x 1.65; 64.0	64	Yes	Yes	No	573088
		Ra < 0.4					Yes	573092
2	Ra < 1.6	Ra < 0.8	50.8 x 1.65; 64.0	64	Yes	Yes	No	573088
		Ra < 0.4					Yes	573092
2	Ra < 1.6	Ra < 0.8	50.8 x 1.65; 64.0	64	Yes	Yes	No	573088
		Ra < 0.4					Yes	573092
2	Ra < 1.6	Ra < 0.8	50.8 x 1.65; 64.0	64	Yes	Yes	No	573088
		Ra < 0.4					Yes	573092
2	Ra < 1.6	Ra < 0.8	50.8 x 1.65; 64.0	64	Yes	Yes	No	573088
		Ra < 0.4					Yes	573092
2	Ra < 1.6	Ra < 0.8	50.8 x 1.65; 64.0	64	Yes	Yes	No	573088
		Ra < 0.4					Yes	573092
2	Ra < 1.6	Ra < 0.8	50.8 x 1.65; 64.0	64	Yes	Yes	No	573088
		Ra < 0.4					Yes	573092
2	Ra < 1.6	Ra < 0.8	50.8 x 1.65; 64.0	64	Yes	Yes	No	573088
		Ra < 0.4					Yes	573092
2	Ra < 1.6	Ra < 0.8	50.8 x 1.65; 64.0	64	Yes	Yes	No	573088
		Ra < 0.4					Yes	573092
2	Ra < 1.6	Ra < 0.8	50.8 x 1.65; 64.0	64	Yes	Yes	No	573088
		Ra < 0.4					Yes	573092
2	Ra < 1.6	Ra < 0.8	50.8 x 1.65; 64.0	64	Yes	Yes	No	573088
		Ra < 0.4					Yes	573092
2	Ra < 1.6	Ra < 0.8	50.8 x 1.65; 64.0	64	Yes	Yes	No	573088
		Ra < 0.4					Yes	573092
2	Ra < 1.6	Ra < 0.8	50.8 x 1.65; 64.0	64	Yes	Yes	No	573088
		Ra < 0.4					Yes	573092
2	Ra < 1.6	Ra < 0.8	50.8 x 1.65; 64.0	64	Yes	Yes	No	573088
		Ra < 0.4					Yes	573092
2	Ra < 1.6	Ra < 0.8	50.8 x 1.65; 64.0	64	Yes	Yes	No	573088
		Ra < 0.4					Yes	573092
2	Ra < 1.6	Ra < 0.8	50.8 x 1.65; 64.0	64	Yes	Yes	No	573088
		Ra < 0.4					Yes	573092
2	Ra < 1.6	Ra < 0.8	50.8 x 1.65; 64.0	64	Yes	Yes	No	573088
		Ra < 0.4					Yes	573092
2	Ra < 1.6	Ra < 0.8	50.8 x 1.65; 64.0	64	Yes	Yes	No	573088
		Ra < 0.4					Yes	573092
2	Ra < 1.6	Ra < 0.8	50.8 x 1.65; 64.0	64	Yes	Yes	No	573088
		Ra < 0.4					Yes	573092
2	Ra < 1.6	Ra < 0.8	50.8 x 1.65; 64.0	64	Yes	Yes	No	573088
		Ra < 0.4					Yes	573092
2	Ra < 1.6	Ra < 0.8	50.8 x 1.65; 64.0	64	Yes	Yes	No	573088
		Ra < 0.4					Yes	573092
2	Ra < 1.6	Ra < 0.8	50.8 x 1.65; 64.0	64	Yes	Yes	No	573088
		Ra < 0.4					Yes	573092
2	Ra < 1.6	Ra < 0.8	50.8 x 1.65; 64.0	64	Yes	Yes	No	573088
		Ra < 0.4					Yes	573092
2	Ra < 1.6	Ra < 0.8	50.8 x 1.65; 64.0	64	Yes	Yes	No	573088
		Ra < 0.4					Yes	573092
2	Ra < 1.6	Ra < 0.8	50.8 x 1.65; 64.0	64	Yes	Yes	No	573088
		Ra < 0.4					Yes	573092
2	Ra < 1.6	Ra < 0.8	50.8 x 1.65; 64.0	64	Yes	Yes	No	573088
		Ra < 0.4					Yes	573092
2	Ra < 1.6	Ra < 0.8	50.8 x 1.65; 64.0	64	Yes	Yes	No	573088
		Ra < 0.4					Yes	573092
2	Ra < 1.6	Ra < 0.8	50.8 x 1.65; 64.0	64	Yes	Yes	No	573088
		Ra < 0.4					Yes	573092
2	Ra < 1.6	Ra < 0.8	50.8 x 1.65; 64.0	64	Yes	Yes	No	573088
		Ra < 0.4					Yes	573092
2	Ra							

Thread process connection acc. to DIN 11851 series A for pipe acc. to DIN 11866 series A (DIN 11850)

Note:

The following variants are equipped with the special functions ATF (acoustic transmission factor) and DF (density factor).

Thread and pipe size	Surface quality		Dimensions ^{1.)} D2 x s; D3	Maximal flow rate	Certifications		Article no.
	Housing, outer surface of measurement tube	Inner surface of measurement tube			3A (28-06)	EHEDG ^{2.)}	
[mm]	[µm]	[µm]	[mm]	[m ³ /h]			
Electrical connection: 1 x 8-pin M12 circular male connector, operating voltage of 12...35 V DC							
65	Ra < 1.6	Ra < 0.8	70.0 x 2.0; Rd 95 x 1/6	123	Yes	Yes	574707
80		Ra < 0.8	85.0 x 2.0; Rd 110 x 1/4	185			574708

1.) D2 for holder; s = thickness; D3: thread connection

2.) The EHEDG compliance is s only valid if used in combination with EHEDG-compliant gaskets from

1. Kieselmann GmbH, Germany (ASEPTO-STAR k-flex upgrade gaskets) or

2. Siersema Componenten Service (S.K.S.) B.V. (Netherlands SKS gasket set DIN 11851 EHEDG with EPDM or FKM inner gasket)

Further versions on request

	Process connection <ul style="list-style-type: none"> For pipe DIN 11850: <ul style="list-style-type: none"> – Clamp DIN 32676 – Clamp DIN 11864-3 – Flange DIN 11864-2 For pipe ISO 1127: <ul style="list-style-type: none"> – Clamp DIN 11864-3 – Flange DIN 11864-2 For pipe ASME BPE: <ul style="list-style-type: none"> – Clamp DIN 11864-3 – Flange DIN 11864-2 For pipe SMS 3008: SMS 3017 		Orifice <ul style="list-style-type: none"> 08...80 mm 3/8...3 inch
			Additional <ul style="list-style-type: none"> Without differentiation factor (DF) Without acoustic transmission factor (ATF) With density and mass flow ATEX/IECEX
			Material <ul style="list-style-type: none"> With inner surface of measurement tube <ul style="list-style-type: none"> – Ra < 0.8 µm (30 µin.) – Ra < 0.4 µm (15 µin.) (electro-polished) according to ISO 4288
			Electrical connection <ul style="list-style-type: none"> 1 x 5-pin M12 male connector 1 x 8-pin M12 male connector

For any other variants, please use the product enquiry form at the end of this data sheet or check the readily available article no. listed in the Bürkert eShop.

10.7. Ordering chart accessories

Description	Article no.	
Display module, Type ME31	265468	
Blind cover in stainless steel 304/1.4301	265467	
Unlocking magnetic key	690309	
System Connect		
Type ME43 Gateway / Interface		
büS/Ethernet (PROFINET, EtherNet/IP, Modbus TCP, EtherCAT)	307390	
büS/Profibus DP	307393	
Type ME61 Display		
Process View Display 3.5" (8.9 cm)	368544	
EDIP Accessories		
büS Stick Set		
USB-büS-Interface Set 1, Type 8923. Detailed information can be found in chapter "9. Product accessories" on page 32.	772426	
USB-büS Interface Set 2, Type 8923 (only büS Stick, cable and büS service cable)	772551	
Connectors		
5-pin M12 straight circular female connector for büS	772416	
5-pin M12 straight circular male connector for büS	772417	
5-pin M12 angled circular female connector for büS	772418	
5-pin M12 angled circular male connector for büS	772419	
büS Y-distributor, 5-pin M12 circular female connector to 5-pin M12 circular male and 5-pin M12 circular connectors	772420	
büS Y-distributor, 5-pin M12 circular female connector to 5-pin M12 circular male and 5-pin M12 circular connectors (power interrupt)	772421	
büS adaptor M12 circular male connector A-coded - M12 circular male connector A-coded	772867	
büS termination, 5-pin M12 circular male connector	772424	
büS termination, 5-pin M12 circular female connector	772425	
Adaptor cable, 8-pin M12 circular female connector - 5-pin M12 circular male connector	773286	
Connectors with cable		
5-pin M12 angled circular female connector moulded on büS cable, with open leads	0.7 m 772626	
5-pin M12 straight circular female connector moulded on büS cable, with open leads	1 m 772409	
	3 m 772410	
	5 m 772411	
	10 m 772412	
Micro USB and 5-pin M12 straight circular male connector moulded on büS cable	0.3 m 773254	
8-pin M12 straight female connector moulded on büS cable, with open leads	2 m 919061	
Extensions		
	5-pin M12 straight circular female and male connectors moulded on büS cable, shielded	0.1 m 772492
		0.2 m 772402
		0.5 m 772403
		1 m 772404
		3 m 772405
		5 m 772406
		10 m 772407
		20 m 772408
Type 1573 Power Supplies		
1 A (NEC Class 2 Power Units)	772361	
2 A (NEC Class 2 Power Units)	772362	
3.8 A (NEC Class 2 Power Units)	772898	
10 A	772698	

Bürkert – Close to You

For up-to-date addresses
please visit us at
www.burkert.com

DTS 1000270652 EN Version: T Status: RL (released | freigegeben | validé) printed: 16.01.2023

