

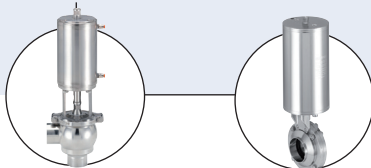

Control head for hygienic process valves

- Universal attachment for hygienic process valves
- Contactless position measurement system with 3 switching points (Teach-In function)
- Color status display
- Manual override to be used with closed housing
- Communication AS-Interface (option)

Type 8681 can be combined with...



Single seat valve
Double seat valve

Butterfly valve
Ball valve

The type 8681 control head is optimized for decentralised automation of hygienic process valves. Thanks to its universal adapter it can be combined with all normal commercial butterfly valves, ball valves, single and double seated valves. With a decentralised automation concept, the control head takes over all pneumatic actuation, feedback and diagnostic functions up to and including field bus communication. The housing is easy to clean and features proven electrical IP protection and chemically resistant materials for use in hygienic processing in food, beverage and pharmaceutical industries. Depending on the process valve type, up to 3 pneumatic actuator chambers can be controlled independently from each other. The switching speeds of both movement directions can be set separately. An inbuilt check valve prevents incorrect switching of process valve actuator chambers which could result from back-pressure.

The process valve switching positions are detected by an inductive, analogue position sensor and reported to the PLC system. Up to 3 switching points can be adjusted automatically by a Teach-In function. Additionally a fourth switching position can be read in and fed back via an external inductive proximity switch. The color status display signals the particular process valve switching position or indicates a diagnostic function such as maintenance required status or fault conditions. The pilot valves are equipped with a manual override. If the device housing is completely closed, the patented magnetically encoded manual override tool can be used to open the process valve from the exterior. Electrical connection can be made via the communication AS-Interface or using discrete wiring.

Technical data

Material	PA, PPO, VA PC CR, EPDM
Body	
Cover / Housing lower part	
Seal	
Control medium	neutral gases, air DIN ISO 8573-1 (filter 5 µm recommended)
Dust concentration	class 5 (<40 µm particle size)
Particle density	class 5 (<10 mg/m ³)
Pressure condensation point	class 3 (<-4°F (-20°C))
Oil concentration	class 5 (<25 mg/m ³)
Supply pressure	36.25 to 116 PSI
Air capacity solenoid valve¹⁾ (supply and exhaust air per solenoid valve adjustable)	110IN/min - for pressurization and exhaust, lifting device 110IN/min - delivery condition 200IN/min - max. typical flow rate (throttle)
Pilot air ports	
Air inlet and outlet	G 1/4
Service ports	G 1/8
Position sensor	non-contact Position Sensor, 3 self-regulated switching points PNP (Teach-In-function) closer (normally open), PNP-output short-circuit proof, with clocking short-circuit protection max. 100 mA per feedback signal
Outlet current	0 to 80 mm
Stroke range	≤ 0.1 mm
Resolution	± 0.5 mm - when using a target for the dimensional drawing, material 1.4021 and a piston rod (Ø 22 mm, material 1.4301) (error refers to the reproducibility of a teach-position)
Total error	
Ambient temperature	14°F to 131°F (-10°C to +55°C)
Installation	As required, preferably with actuator in upright position

¹⁾ QNn-value acc. to the definition with decrease in pressure from 101.5 to 87 PSI absolute with 68°F (20°C).

Technical data, continued

Type of protection	IP 65/67 acc. to EN 60529
Protection class	3 acc. to VDE 0580
Fieldbus communication	AS-Interface, DeviceNet (in preparation)
Conformity	acc. to CE in compliance with EMV2004/108/EG
Ignition protection	II 3G Ex nA IIC T4 II 3D Ex tD A22 T135°C

Without fieldbus communication	
Operating voltages	12 to 28 VDC
Residual ripple with DC	10 %, no technical direct current
Power consumption	< 5 W (acc. to version and operating status see instruction manual)
Valve control inputs (Y1 - Y3) Signal level - active Signal level - inactive Impedance	U < 5 V, max. 24 V DC + 10% U < 5 V U > 30 kOhm
Outputs / binary feedback signals Design Switchable output current Output voltage -active Output voltage -inactive	S1 out - S4 out Normally open contact, PNP output short-circuit proof with self-clocking short circuit protection max. 100 mA per feedback signal ≥ (operating voltage - 2 V) max. 1 V in unloaded state
Input / proximity switches (external initiator: S4 in) Power supply Current carrying capacity, sensor power supply Design Input current 1 signal Input voltage 1 signal Input current 0 signal Input voltage 0 signal	Voltage present at control head - 10 % max. 90 mA short-circuit protection DC 2- and 3-conductor, NO or NC (factory setting NO), PNP output $I_{\text{Sensor}} > 6.5 \text{ mA}$, limited internally to 10 mA $U_{\text{Sensor}} > 10 \text{ V}$ $I_{\text{Sensor}} < 4 \text{ mA}$ $U_{\text{Sensor}} < 5 \text{ V}$
Electrical connection Multi-pole Cable gland	M12 12-pin with cable 8 cm, 1 x M16 x 1.5 cable glands for external initiator (clamping range 3 ... 6 mm) M16 x 1.5 (cable-Ø 5 ... 10 mm, screw terminals 0.14 ... 1.5 mm ²), 1 x M16 x 1.5 cable glands for external initiator (clamping range 3 ... 6 mm)

With fieldbus communication; AS-Interface	
Profil	p-7.A.E (A/B slave max. 62 slaves/master) p-7.F.F (max. 31 slaves/master)
Operating voltages above bus line from bus signal separated	as Specification reversible (Jumper)
Power consumption equipment without external power supply Max. Current consumption Current consumption in normal operation (acc. to reduction of electric current; valve + 1 end position achieved)	240 mA (incl. external initiator with 90 mA) ≤ 150 mA 3 valves activated, 1 position feedback with LED display, no external initiator
Power consumption equipment with external power supply The power supply unit must include a secure disconnect in accordance with IEC 364-4-41. It must conform to the SELV standard. The ground potential may not have an earth connection.	19.2 V DC up to 31.6 V DC ≤ 100 mA 24 V DC ≤ 150 mA type.
Output Contact rating Watch-dog function	0.8 W with AS-Interface, per Solenoid Valve (0.9 W Switch-on power) integrated
Input / proximity switches (external Initiator: S4 in) Power supply Current carrying capacity, sensor power supply Design Input current 1 signal Input voltage 1 signal Input current 0 signal Input voltage 0 signal	AS interface voltage present at control head - 10 % max. 30 mA short-circuit protection DC 2- and 3-conductor, NO or NC (factory setting NO), PNP output $I_{\text{Sensor}} > 6.5 \text{ mA}$, limited internally to 10 mA $U_{\text{Sensor}} > 10 \text{ V}$ $I_{\text{Sensor}} < 4 \text{ mA}$ $U_{\text{Sensor}} < 5 \text{ V}$
Electrical connection (ASI flat cable clip at cable 80cm as standard)	M12 4-pin at cable 8 cm (acc. 0.3 m cable length acc. to AS-Interface Specification) 1 x M 16 x 1.5 cable glands for external initiator clamping range 3 ... 6 mm. M12 4-pin at cable 80 cm (acc. 1.0 m cable length acc. to AS-Interface Specification) 1 x M 16 x 1.5 cable glands for external initiator clamping range 3 ... 6 mm.

Technical data, continued

With fieldbus communication; DeviceNet	
Specification	DeviceNet specification Release April 2010. (63 slaves/master)
Operating voltage	11 to 25 V DC (as per specification)
Max. power consumption	240 mA at 24 V DC
Outputs (from master perspective) / solenoid valves: Max. switching capacity Typ. continuous output Output reduction via DeviceNet interface Pull-in current	1.0 W 0.8 W electronics integrated 120 mA typ. / 200 ms (3 valves)
Holding current	100 mA typ. at 24 V DC (3 valves)
Electrical connection	80cm flying lead with Multi-pole M12 x 5 pole plug according to IEC 61076-2-101 for DeviceNet bus and power supply M16 x 1.5 cable gland / SW19 for external initiator input

Bit configuration

Databit	D3	D2	D1	D0
Input	external initiator S4	position 3	position 2	position 1
Output	not configured	solenoid valve 3	solenoid valve 2	solenoid valve 1
Parameterbit	D3	D2	D1	D0
Output	not configured	not configured	not configured	not configured

Programming data

Databit	Programming data with 62 Slaves AS-Interface - apparat for A/B-Slave- addressing (standard device)	Programming data with 31 Slaves AS-Interface (optional)
E/A - configuration	7 hex (4 Inputs / 4 Outputs) see bit configuration chart	7 hex (4 Inputs / 4 Outputs) see bit configuration chart
ID-code	A hex	F hex
combinative ID-code 1	7 hex	(F hex)
combinative ID-code 2	E hex	(F hex)
profil	p-7.A.E	p-7.F.F

Flange for process valve

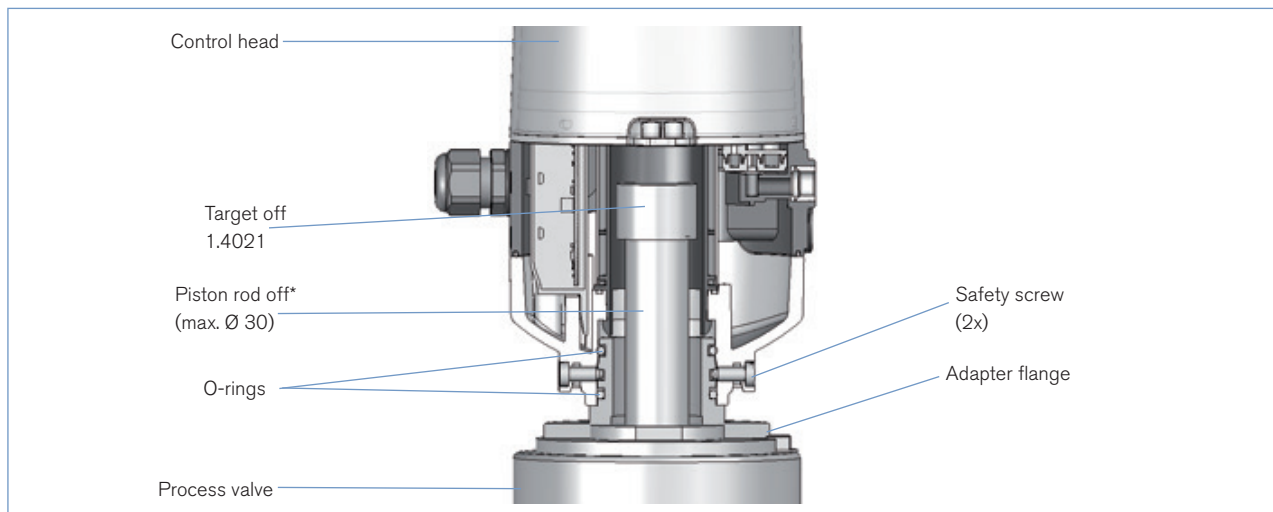

*The fastening materials for target and piston rod may not be made of material with very good electrical conductivity (e.g. copper, aluminum) or of ferromagnetic material. Stainless steels such as e.g. 1.4404 are suitable.

Materials

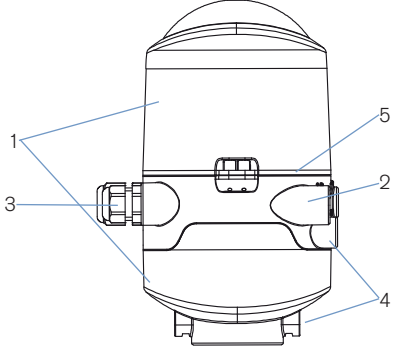

1 Cover / Housing lower part	PC
2 Fluid part	PPO
3 Cable glands	PA
4 Screws / screw-in threaded port	VA
5 Seal	EPDM, CR

Connections

Without fieldbus communication

Cable glands

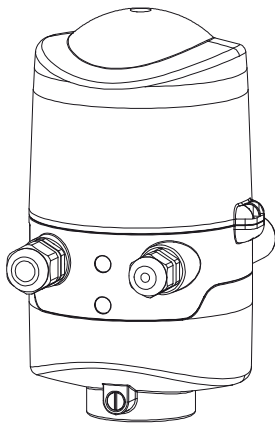

Connection left: Voltage, signals
Connection right: external initiator

Cable glands with multi-pole connection

Version with 12 pin plug (24 V)¹⁾

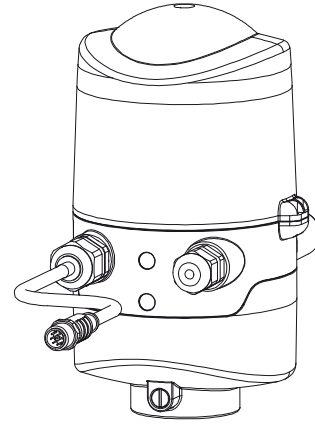

Connection left: Voltage, signals
Connection right: external initiator

¹⁾ M12 plug acc. IEC 61076-2-101, 12 pin at cable 8 cm

Multi-pole connection M12, 12-pin

In- and Output signal for superordinated control (SPS):

12-pin terminal M12 x 0.75 - male (acc. IEC 61076-2-101)

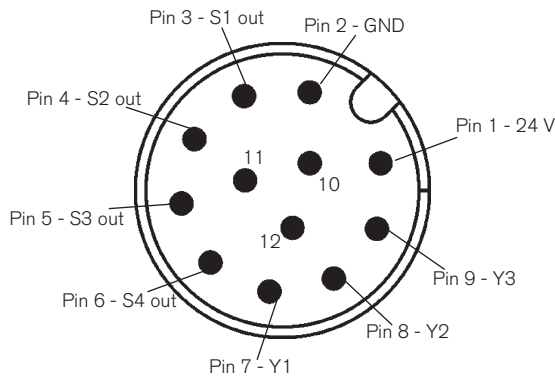

Pin	Description	Configuration
1	24 V	power supply 24 V
2	GND	GND
3	S1 out	Output position S1
4	S2 out	Output position S2
5	S3 out	Output position S3 ¹⁾
6	S4 out	Output externer Initiator S4
7	Y1	Input Solenoid valve 1
8	Y2	Input Solenoid valve 2
9	Y3	Input Solenoid valve 3
10		not configured
11		not configured
12		not configured

¹⁾ in ordering option "analog", S3 out is a analog signal instead of a binary signal

Connections, continued

Without fieldbus communication Cable glands

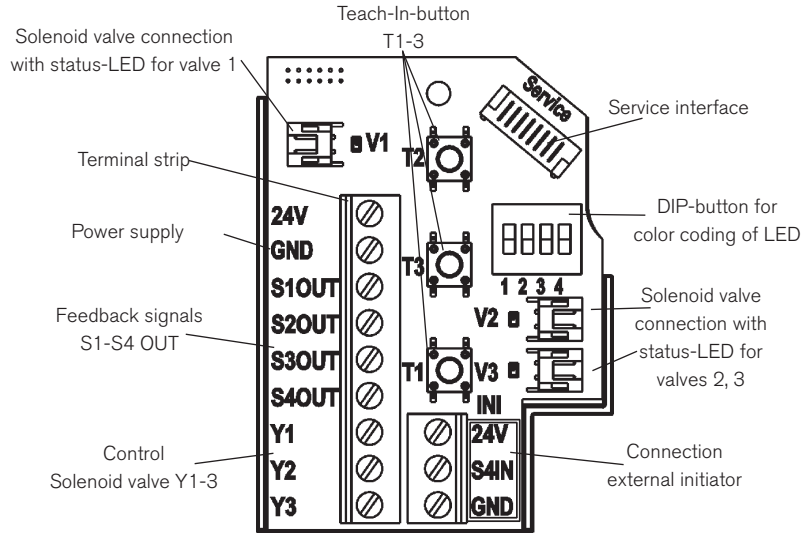

Description Terminal strip	Configuration
24 V	Power consumption 24 V
GND	GND
S1 OUT	Output position 1
S2 OUT	Output position 2
S3 OUT	Output position 3 ¹⁾
S4 OUT	Output external initiator
Y1	Input Solenoid valve 1
Y2	Input Solenoid valve 2
Y3	Input Solenoid valve 3

Description Terminal strip	Configuration
24 V	Power consumption 24 V for external initiator
S4 IN	Input external initiator
GND	GND external initiator

¹⁾ in ordering option "analog", S3 out is a analog signal instead of a binary signal

With fieldbus communication AS-Interface

with multi-pole connection¹⁾
(M12-plug acc. IEC 61076-2-101, 4-pin) at cable 8 cm

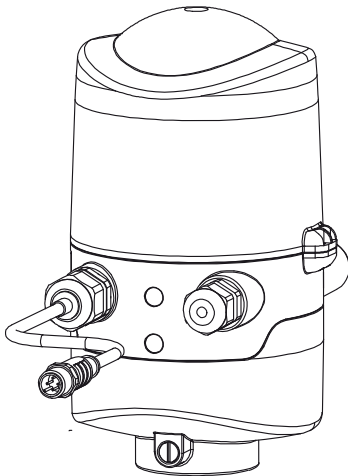

left: AS-Interface

right: external initiator

with multi-pole connection
(M12-plug acc. IEC 61076-2-101, 4-pin) with mounted flat cable clip at cable 80 cm

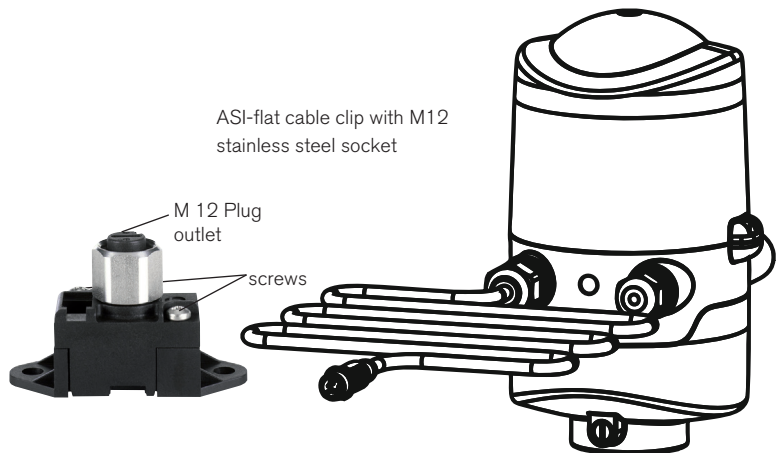

left: AS-Interface

right: external initiator

¹⁾on request

Connections, continued

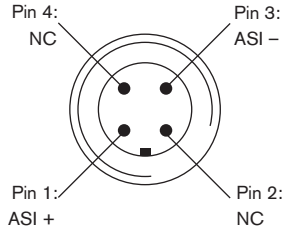

Fieldbus connection
Power consumption over Fieldbus

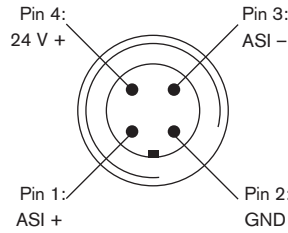

Fieldbus connection
with external Power consumption

Pin	Configuration (Consumption over Fieldbus)	Configuration (external Power consumption)	Wire color
1	AS-Interface - ASI +	AS-Interface - ASI +	brown
2	not configured	GND	white
3	AS-Interface - ASI -	AS-Interface - ASI -	blue
4	not configured	24 V +	black

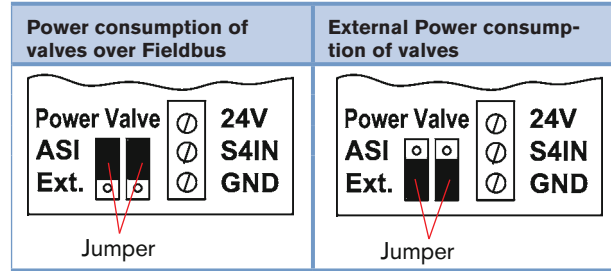

Pneumatic connection

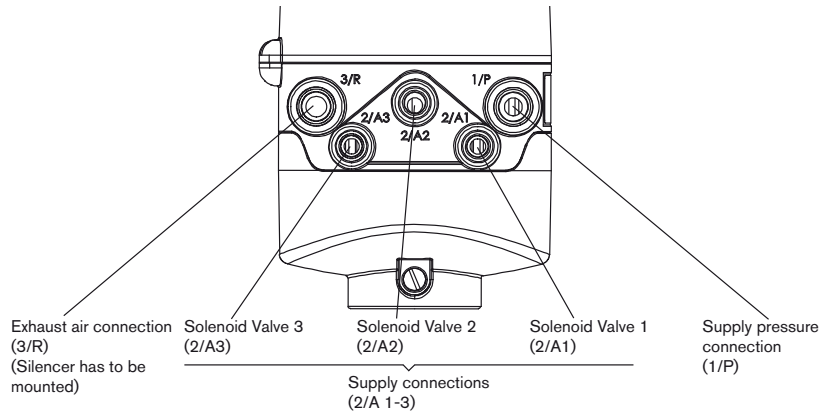

Multi-pole connection DeviceNet

The control head features a 5-pole multi-pole circular plug (M12 x 1 circular plug, 5-pole, male) to a 80 cm long cable. The configuration conforms to the DeviceNet specification.

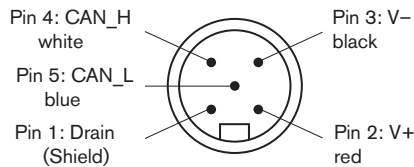

Pin	Signal
1	Shielding
2	V +
3	V -
4	CAN_H
5	CAN_L

Bus connection of DeviceNet with external power supply

Magnetic manual override

Activation / De-Activation Solenoid valve 1 (process valve maintenance)

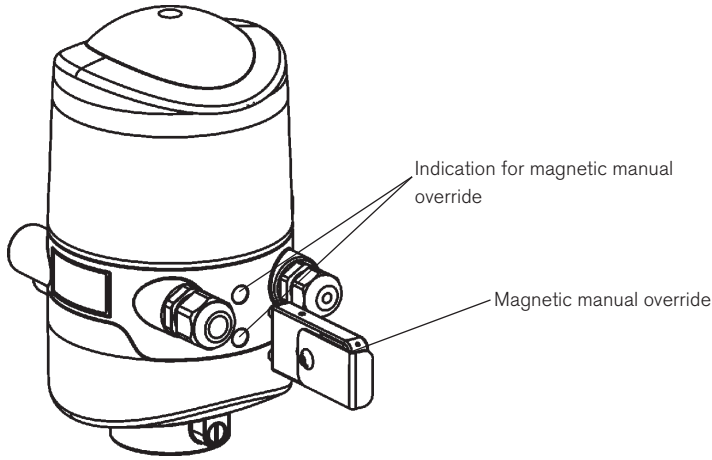

Version	Item no.
Magnetic manual override	196 490

Ordering chart Control head type 8681 (other versions on request)

Communication	Supply voltage	Connection	ATEX zone 2/22 cat. 3	number Solenoid valve	Feedback	Item no.
without	12 to 28 V DC	cable gland	without	0	3 int. + 1 ext.	196 410
			without	1	3 int. + 1 ext.	196 411
			without	2	3 int. + 1 ext.	196 412
			without	3	3 int. + 1 ext.	196 413
			with	1	3 int. + 1 ext.	196 415
without	12 to 28 V DC	M12, 12-pin, cable 8 cm	without	0	3 int. + 1 ext.	196 420
			without	1	3 int. + 1 ext.	196 421
			without	2	3 int. + 1 ext.	196 422
			without	3	3 int. + 1 ext.	196 423
			with	1	3 int. + 1 ext.	196 425
AS-Interface (62 slaves)	29.5 to 31.6 V DC	version with ASI flat cable clip and cable 80 cm	without	0	3 int. + 1 ext.	196 430
			without	1	3 int. + 1 ext.	196 431
			without	2	3 int. + 1 ext.	196 432
			without	3	3 int. + 1 ext.	196 433
			with	1	3 int. + 1 ext.	196 435
DN-Interface (63 slaves)	11 to 25 V DC	version with DN plug and flying lead, 80cm	without	1	3 int. + 1 ext.	196 451
			without	2	3 int. + 1 ext.	196 452
			without	3	3 int. + 1 ext.	196 453

i Further versions on request

- > Additional**
- AS-Interface: connection M12 4-pin cable 8 cm
- AS-Interface without cutting binder
- Power consumption 120 V AC
- analog (4...20 mA) instead of binary Feedback signal only 24 V version
- DeviceNet

Ordering chart for accessories

Version	Item no.
Silencer PE G 1/4	780 780
Knock out plugs PP G 1/8	770 901
Rotary fitting brass nickel-plated G 1/4 for Ø Tube 8/6	780 084
Rotary fitting brass nickel-plated G 1/8 for Ø Tube 6/4	780 082
Universal VA-flange with O-ring	196 495
Target for type 8681 over 1.4021	196 494
Magnetic manual override tool	196 490
Cable 27 cm (8 cm external) with 12 pin M12 plug for 24 V DC	217 574
Cable 99 cm (80 cm external) with 4 pin M12 plug for ASi	217 572
Cable 27 cm (8 cm external) with 4 pin M12 plug for ASi	217 573
ASi- Flat Cable Clamp with M12 stainless steel connector	799 646
Cable 99 cm (80 cm external) with 5 pol M12 plug for DeviceNet	218 187
USB Adapter kit PC communication	196 496
Bluetooth-Adapter kit Smartphone-communication	196 497

Dimensions [mm]

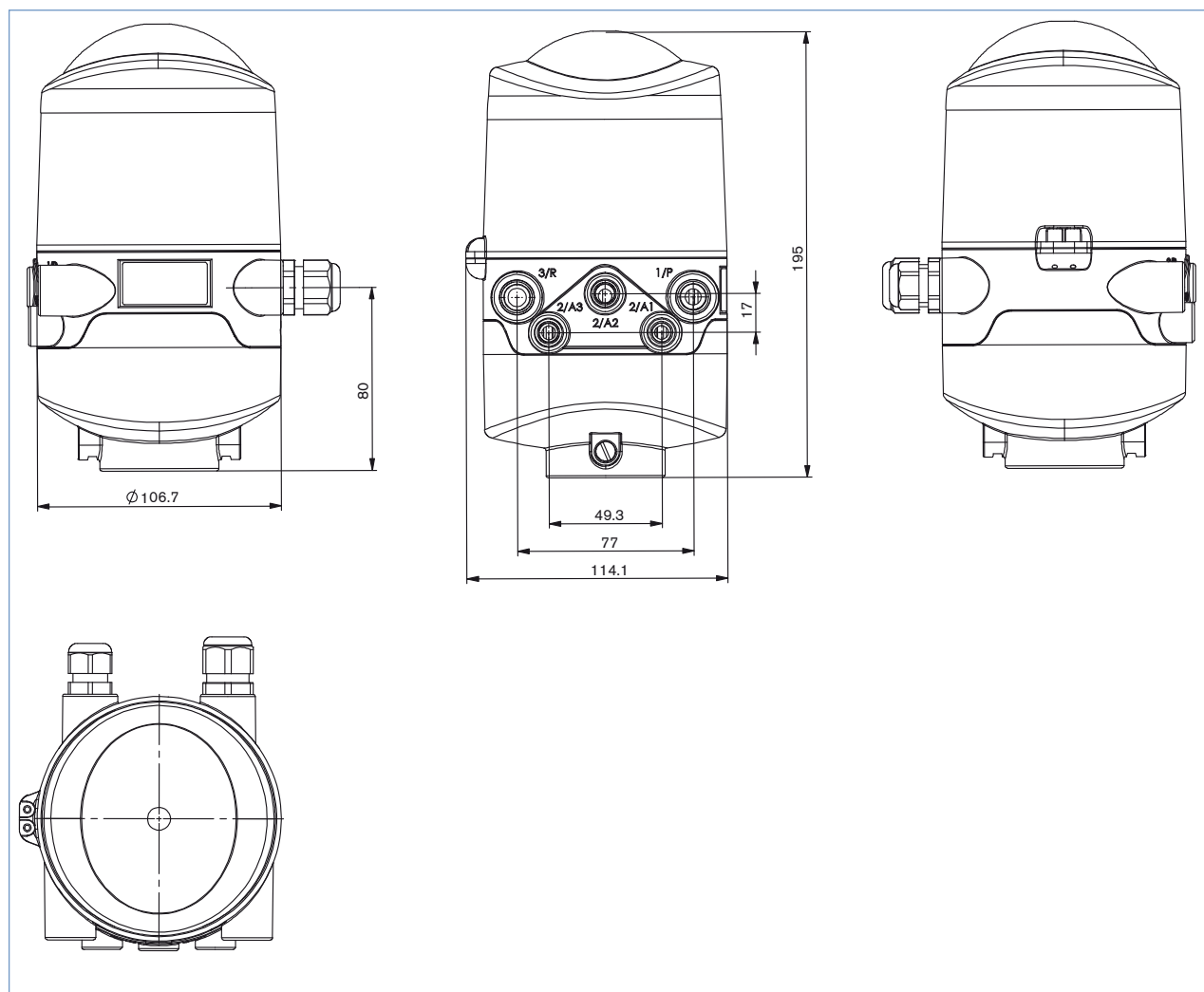

Dimensions [mm], continued

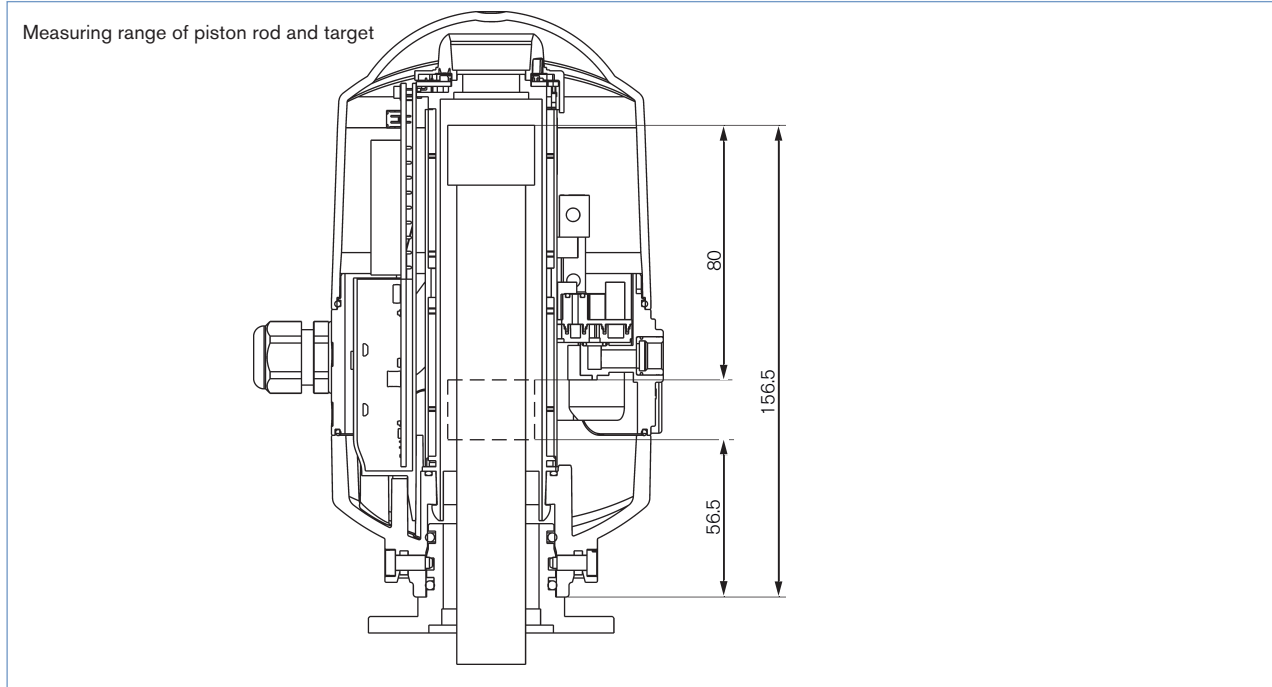

Dimensions [mm], accessory

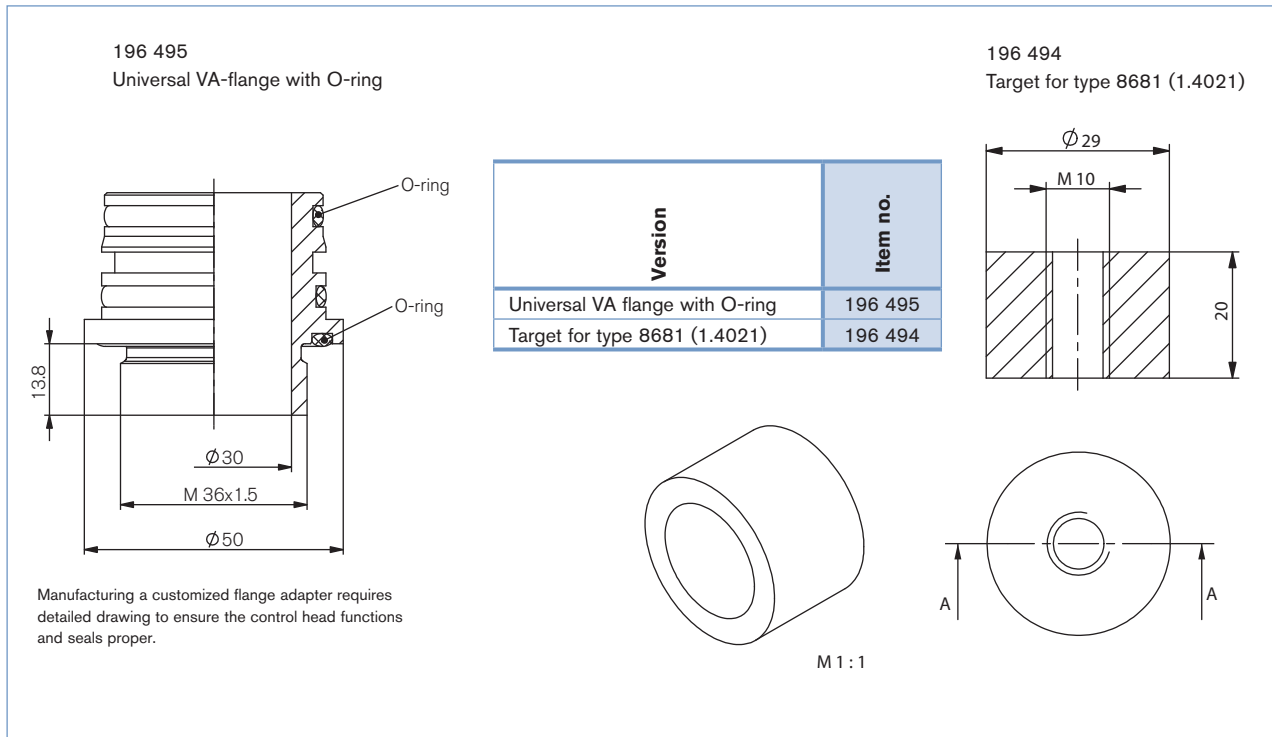

DTS 1000171822 EN Version: C Status: RL (released | freigegeben | validé) printed: 26.03.2021

To find your nearest Burkert facility, click on the orange box →

www.burkert-usa.com

DISTRIBUTED BY

HARCO

ENTERPRISES LTD.

1-800-361-5361

In case of special application conditions, please consult for advice.

We reserve the right to make technical changes without notice.
© Christian Bürkert GmbH & Co. KG