



DISTRIBUTED BY



ENTERPRISES LTD.

1-800-361-5361

Alfa Laval SaniJet 20

Rotary jet heads

Introduction

The Alfa Laval SaniJet 20 is a rotary jet head tank cleaning machine for hygienic environments. Built to clean tanks with capacities from 5-30 m³ it combines pressure and flow to create high-impact cleaning jets that rotate in a repeatable and reliable 360-degree cleaning pattern.

The SaniJet 20 minimizes the consumption of water, and cleaning media. Easy to customize to meet customer requirements, it allows companies to spend less time cleaning and more time producing.

Applications

The Alfa Laval SaniJet 20 is designed for the removal of the toughest residues from hygienic tanks across a broad range of industries, such as in yeast propagation plants and in the food and beverage industries.

Benefits

- 60% faster cleaning = more time for production
- Saves up to 70% of your cleaning cost
- High-impact cleaning in a 360° repeatable cleaning pattern
- Cleaning process can be validated using Alfa Laval Rotacheck

Standard design

The choice of nozzle diameters can optimize jet impact length and flow rate at the desired pressure.

Alfa Laval offers a wide range of tank cleaning machines suitable for different duties and industries. An alternative that offers performance similar to the Alfa Laval SaniJet 20 is the Alfa Laval SaniJet 20 UltraPure for hygienic applications that require full traceability of product-contacted parts and smooth qualification and validation processes through the Alfa Laval Q-doc documentation package.

Certificates

2.2 material certificate, Q-doc and ATEX.

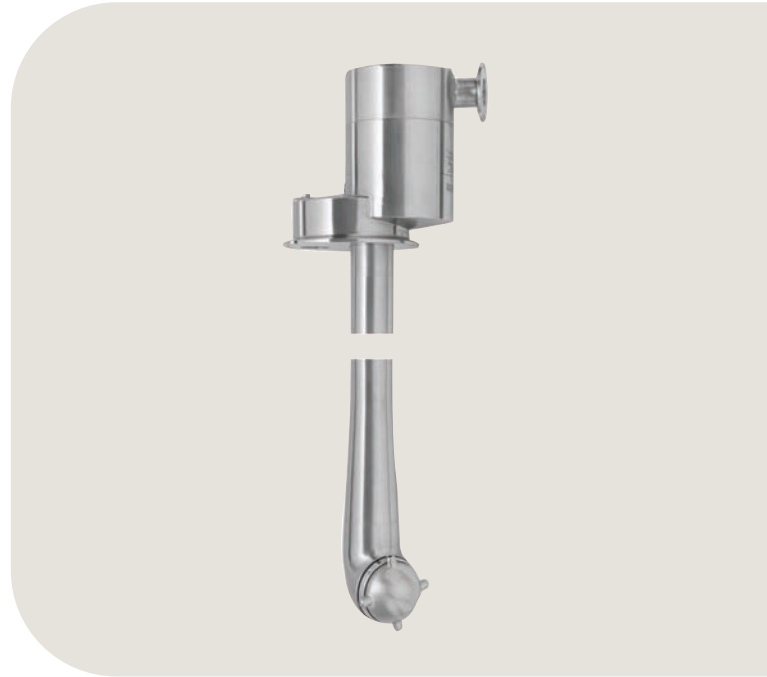

Working principle

The high-impact jet stream from the rotary jet head covers the entire surface 360° of the tank interior in a successively denser pattern. This achieves a powerful mechanical impact with a low volume of water and cleaning media.

The flow of the cleaning fluid makes the nozzles perform a geared rotation around the vertical and horizontal axes. In the first cycle, the nozzles lay out a course pattern on the tank surface. The subsequent cycles gradually make the pattern denser until at full cleaning pattern is reached.

Once the full cleaning pattern is reached, the machine will start over again and continue to perform the next full cleaning pattern.

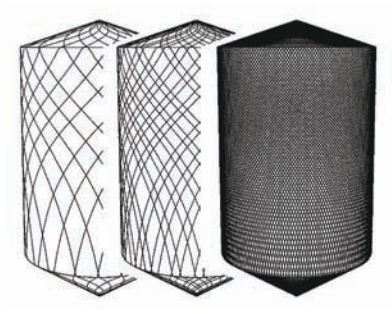

TECHNICAL DATA

Lubricant	
Machine:	Self-lubricating with the cleaning fluid
Air motor:	Must NOT be operated non-lubricated

Surface finish	
Product contact parts:	Ra 0.8 µm

Impact throw length	
Impact throw length:	1.5 - 4 m.

Min. tank opening	
Min. tank opening:	4" Clamp w. rotachek 3" clamp - rotachek N/A

Pressure	
CIP media working pressure:	3 - 13 bar
CIP media recommended pressure:	5 - 8 bar

Air driven. Air quality	
Clean, filtered max.:	50 µm
Dry, dew point max.:	5 °C Must NOT be operated non-lubricated. MUST be lubricated
Air supply pressure:	Max. 6 bar
Air consumption at max. speed:	6 l/sec. (22 m ³ /h)
Adjustable speed:	3 - 14 RPM
Cleaning time:	4 - 18 min. (adjustable)

PHYSICAL DATA

Materials	
316L (UNS S31603), PEEK ¹ , Titanium Ti-GL	
Sealing:	EPDM ¹ (standard), FPM ¹ FFKM ¹
¹ FDA compliance 21CFR§177	

Temperature	
Max. working temperature:	90 °C
Max. ambient temperature:	140 °C

Weight	
Media-driven machine:	11 - 18 kg
Air-driven machine:	11.7 - 19.2 kg

Connections

Inlet connection:	Clamp: 1" ISO 2852
Tank connection:	Clamp: 4" ISO 2852
Tank connection:	Clamp: 3" ¹ ISO 2852

¹ Note! 3" Tank connection has no possibility of integrated rotacheck.

Caution

Avoid hydraulic shock, hard and abrasive particles in the cleaning liquid, as this can cause increased wear and/or damage of internal mechanisms. In general, a filter in the supply line is recommended. Do not use for gas evacuation or air dispersion. For steaming we refer to the manual.

Options

- Electronic rotation sensor to verify 3D coverage
- Improved surface finish
- 3.1 certification for metallic parts by request
- With FFKM or FPM seal ring
- ATEX

Qualification Documentation

Documentation specification

	Equipment Documentation includes:
	<ul style="list-style-type: none">• EN 1935/2004 DoC• EN 10204 type 3.1 inspection Certificate and DoC• FDA DoC
Q-doc	<ul style="list-style-type: none">• GMP EC 2023/2006 DoC• EU 10/2011 DoC• ADI DoC• QC DoC

	ATEX approved machine for use in explosive atmospheres
	Media/Air driven:
	Cleaning unit:
	Catagory 1 for installation in zone 0/20 in accordance with Directive 2014/34/EU
	II 1G Ex h IIC 85 °C ... 175 °C Ga
ATEX	II 1D Ex h IIIC T85 °C ... T140 °C Da
	Air driven:
	Air motor unit:
	Catagory 2 for installation in zone 1/21 in accordance with Directive 2014/34/EU
	II 2G Ex h IIC T4 Ga
	II 2D Ex h IIIC T135 °C Da

Flow Rate

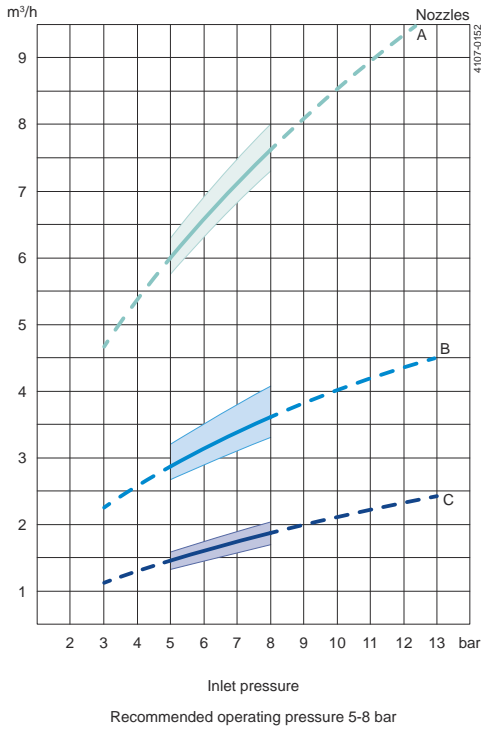

A = 4 x Ø4.2 mm
 B = 2 x Ø3.8 mm LS
 C = 2 x Ø2.0 mm

Cleaning Time, Complete Pattern, Media driven

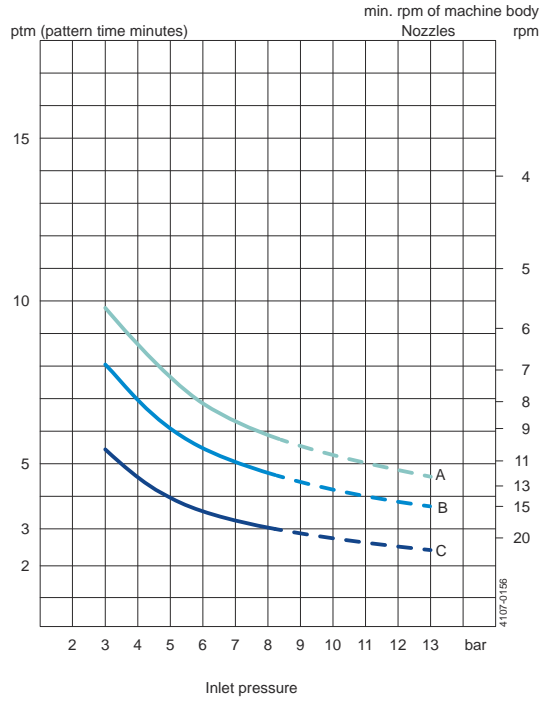

A = 4 x Ø4.2 mm
 B = 2 x Ø3.8 mm LS
 C = 2 x Ø2.0 mm

Impact Throw Length, Media Driven

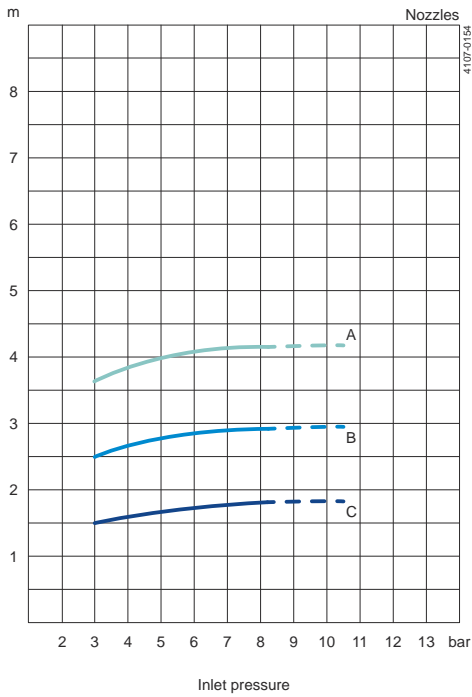

A = 4 x Ø4.2 mm
 B = 2 x Ø3.8 mm LS
 C = 2 x Ø2.0 mm

Impact Throw Length, Air Driven

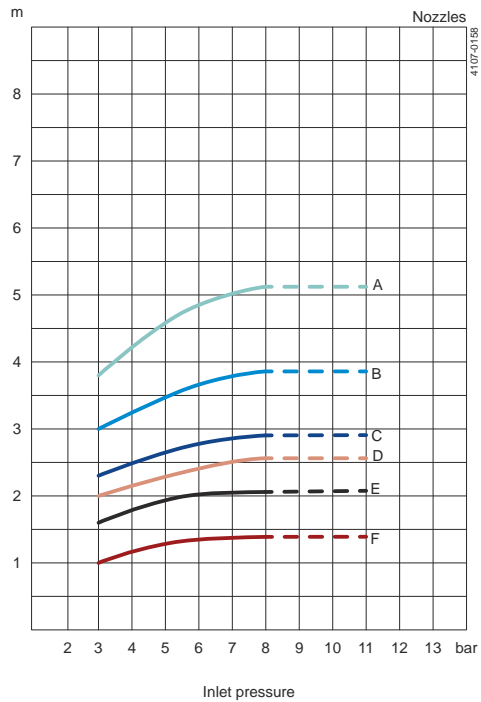

A = (5 rpm) 4 x Ø4.2 mm
 B = (5 rpm) 2 x Ø3.8 mm
 C = (16 rpm) 4 x Ø4.2 mm
 D = (5 rpm) 2 x Ø2.0 mm
 E = (16 rpm) 2 x Ø3.8 mm
 F = (16 rpm) 2 x Ø2.0 mm

Dimensions (mm)

Media Driven

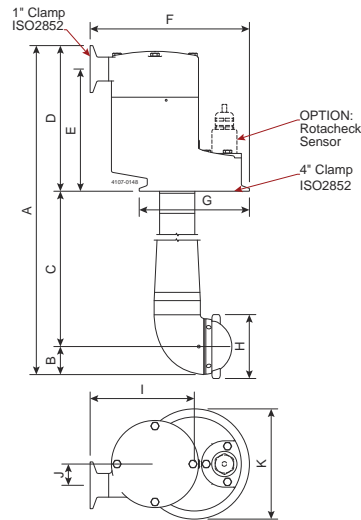

A	B	C	D	E	F	G	H	I	J	K
537 - 687 - 887 - 1187 - 1387 - 1687	31	350 - 500 - 700 - 1000 - 1200 - 1500	157.25	132	172	Ø119	Ø69	112.5	23	Ø119

Air Driven

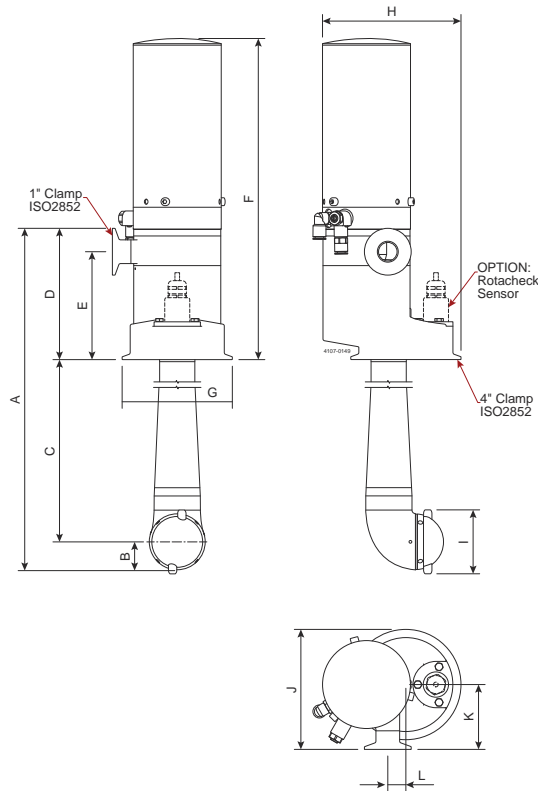

A	B	C	D	E	F	G	H	I	J	K	L
523 - 673 - 873 - 1173 - 1376 - 1673	31	360 - 500 - 700 - 1000 - 1200 - 1500	142	117	340	Ø119	168	Ø69	130	70	19.5

DISTRIBUTED BY

ENTERPRISES LTD.
1-800-361-5361

This document and its contents are subject to copyrights and other intellectual property rights owned by Alfa Laval AB (publ) or any of its affiliates (jointly "Alfa Laval"). No part of this document may be copied, re-produced or transmitted in any form or by any means, or for any purpose, without Alfa Laval's prior express written permission. Information and services provided in this document are made as a benefit and service to the user, and no representations or warranties are made about the accuracy or suitability of this information and these services for any purpose. All rights are reserved.

200006926-3-EN-GB

© Alfa Laval AB

How to contact Alfa Laval

Up-to-date Alfa Laval contact details for all countries are always available on our website at www.alfalaval.com