

Supply Tubes

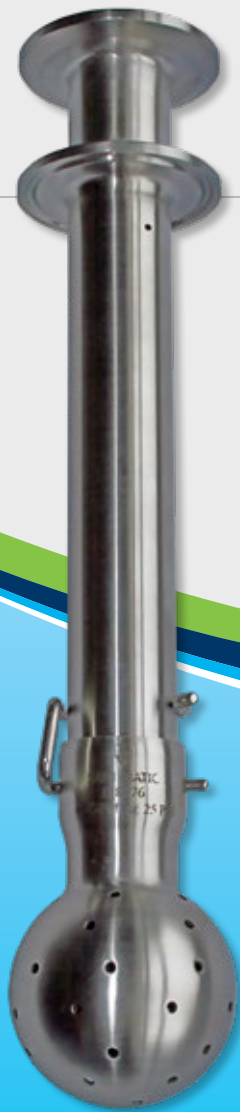

Precise Spray Ball Placement for a Complete Clean

Determining the proper supply tube for your spraying system is critical for thorough cleaning.

Even though the spray device is a major part of your tank/vessel cleaning solution, all spray devices must be properly positioned to maximize their effectiveness. All Sani-Matic Supply Tubes are made to order, which allows for precise spray device placement. Our Supply Tubes are also highly customizable and can be created with multiple device options, pass-through spray balls, reducers, and more. We make all our Supply Tubes in our Sun Prairie, WI facility, allowing for a quick delivery.



Sani-Matic is authorized to carry a 3-A symbol for our Supply Tube design, but let your Sani-Matic Representative know if your application requires 3-A to ensure your custom spray assembly meets these requirements.

DISTRIBUTED BY

HARCO
ENTERPRISES LTD.

1-800-361-5361



QUICK TIPS

How do you properly clean tanks with baffles or agitators?

When tanks have baffles or agitators, a shadowing effect occurs within the tank and leaves areas without full spray coverage. Using multiple spray assemblies for full spray coverage combats shadowing.

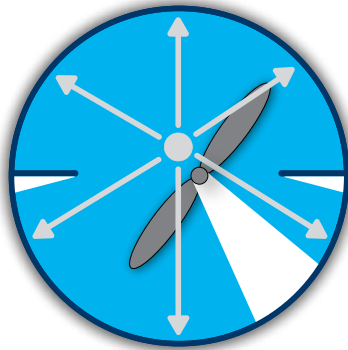

Shadowing

This top view of a tank with baffles and an agitator shows the shadowing of spray due to obstructions within the tank.

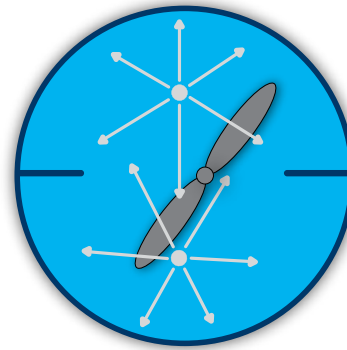

Multiple Spray Assemblies

For complete coverage, multiple spray sources are needed to compensate for the shadowing effect.

GOOD TO KNOW

- **Material:** 316Lss
- Supply tubes may require longer lead times if engineering for specific tank requirements.
- Sani-Matic supply tubes are used with static spray balls, rotary, and jet spray devices.
- With double ball tees, flow rate is divided between both spray balls.

Supply Tube Model Number Key

Example Model #:
ST-150-300-SC-TC-12-OS-32-MP

		1	2	3	4	5	6	7	8	9	10	11	12	13	14	15	16	17	18	19	20
1, 2	Component Model																				
	ST	Supply Tube																			
3-5	Tube Diameter																				
	050	0.50" Tube Diameter ¹																			
	075	0.75" Tube Diameter																			
	100	1.00" Tube Diameter																			
	150	1.50" Tube Diameter																			
	200	2.00" Tube Diameter																			
	250	2.50" Tube Diameter																			
6, 7	Tank Connection Size																				
	00	No Connection																			
	15	1.50" Tank Connection																			
	20	2.00" Tank Connection																			
	25	2.50" Tank Connection																			
	30	3.00" Tank Connection																			
	40	4.00" Tank Connection																			
	60	6.00" Tank Connection																			
8	Tank Connection Type																				
	0	Tri-Clamp (Standard)																			
	X	No Connection																			
9, 10	Spray Ball Connection Type																				
	SC	Slip Collar (Standard)																			
	AW	Slip Collar (AWH)																			
	CS	Slip Collar (Custom)																			
	BW	Butt Weld																			
	TC	Tri-Clamp ¹																			
	HC	Half Coupling (FNPT) ¹																			
	PN	Pipe Nipple (MNPT) ¹																			
11, 12	External Connection Type																				
	TC	Tri-Clamp (Standard)																			
	BW	Butt Weld																			
	HC	Half Coupling (FNPT) ¹																			
	PN	Pipe Nipple (MNPT) ¹																			
13, 14	Internal Length																				
	##	Custom Internal Length (inches)																			
15, 16	External Length																				
	OS	Standard Length (Standard)																			
	##	Custom Length (inches)																			
17, 18	Finish																				
	32	32 µin Ra (Standard)																			
	20	20 µin Ra*																			
	15	15 µin Ra*																			
19, 20	Polish																				
	MP	Mechanical Polish (Standard)																			
	EP	Electropolish*																			

***Non-stock product option. Longer lead times apply.**

Specify custom length values when ordering.

¹ Does not conform to 3-A standard.

NOTE: Supply Tubes are built to order and are non-returnable.

Supply Tube Hole Information - For Slip Collar (Standard) Spray Ball Connection Type

Tube A (OD)	Distance B	Drill Diameter C
1/2"	3/16"	5/64"
3/4"	3/16"	9/64"
1"	5/16"	9/64"
1 1/2"	11/16"	13/64"
2"	15/16"	13/64"

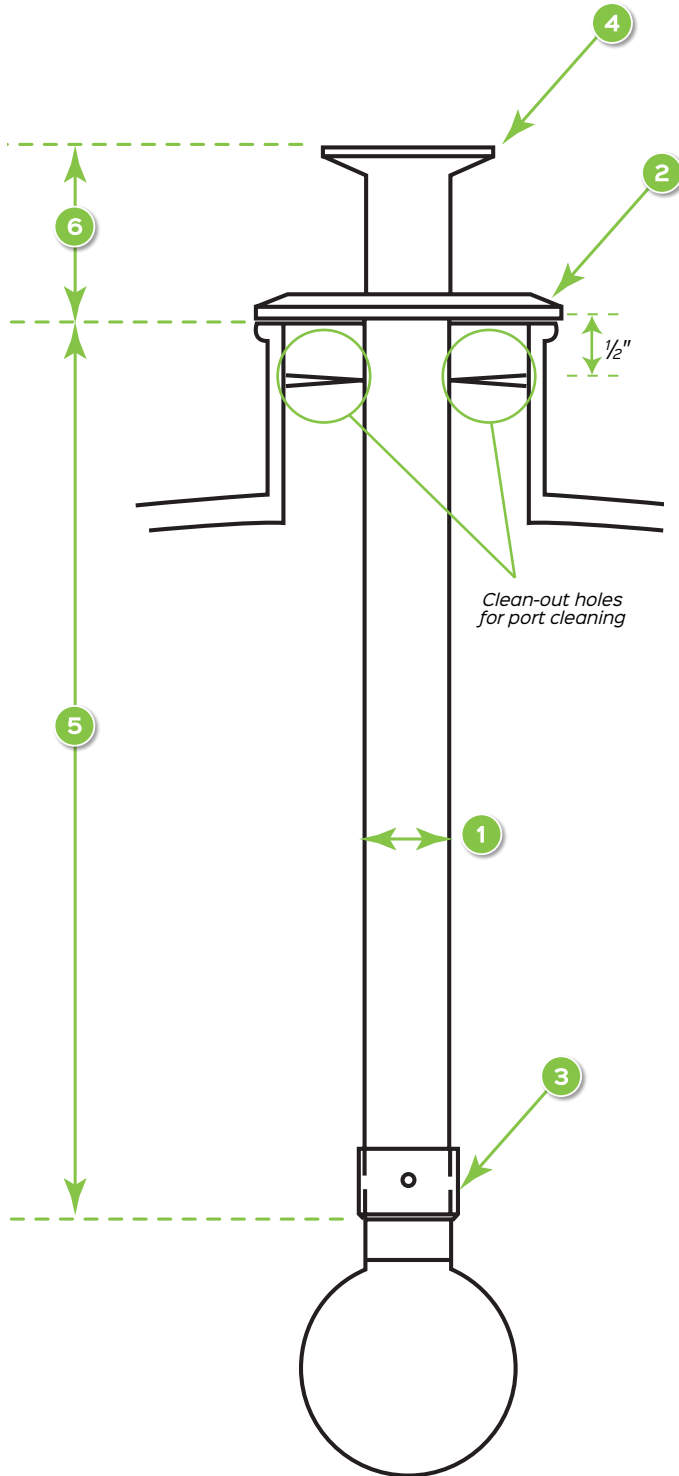
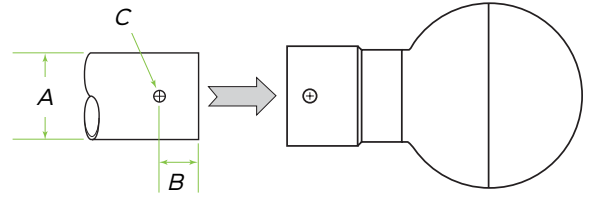

- 1 Tube Diameter
- 2 Tank Connection
- 3 Spray Ball Connection
- 4 External Connection
- 5 Internal Length (Length of tube within the tank)
- 6 External Length (Length of tube outside the tank)

Standard External Lengths

The below table lists out the 6 External Length which varies based on 2 Tank Connection size.

2 Tank Connection Size	6 External Length
1.5" - 3.0"	1 3/4"
4.0"	1 13/16"
6.0"	1 15/16"

Double Ball Tee Model Number Key

Example Model #:
DT-150-SC-12-12-32-MP

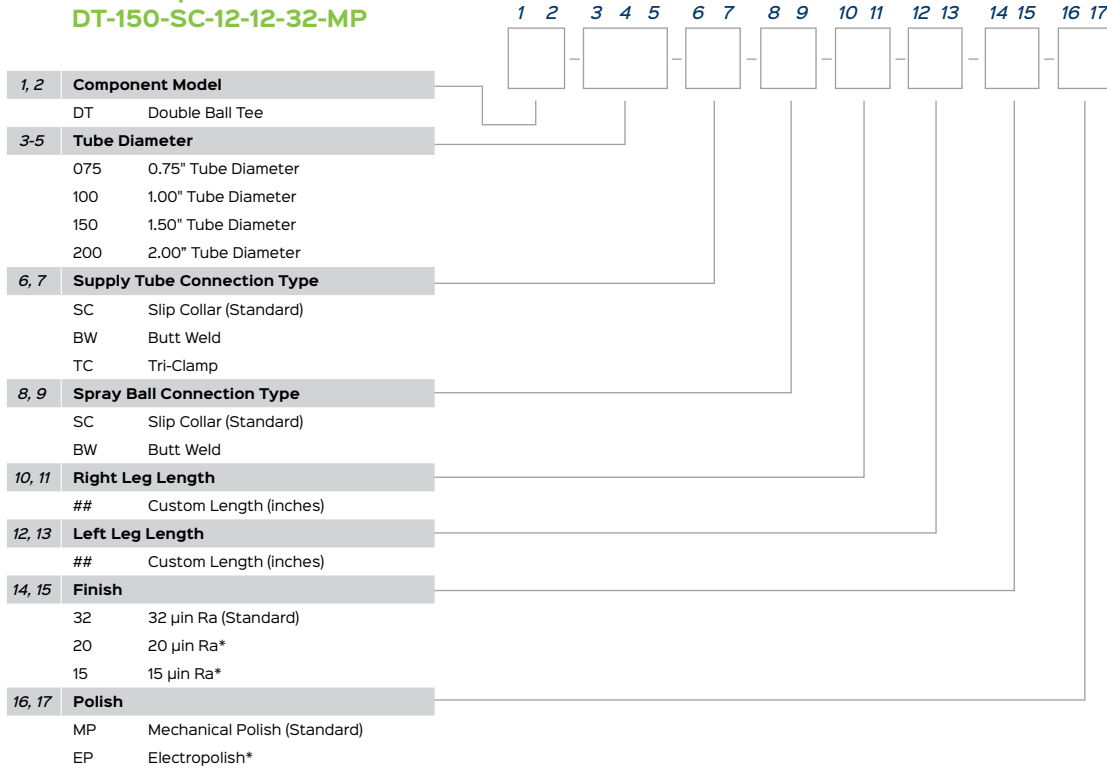

***Non-stock product option. Longer lead times apply.**

Specify custom length values when ordering.

NOTE: No clips are included with double ball tee assemblies and are to be ordered separately as required.

NOTE: Double Ball Tees are built to order and are non-returnable.

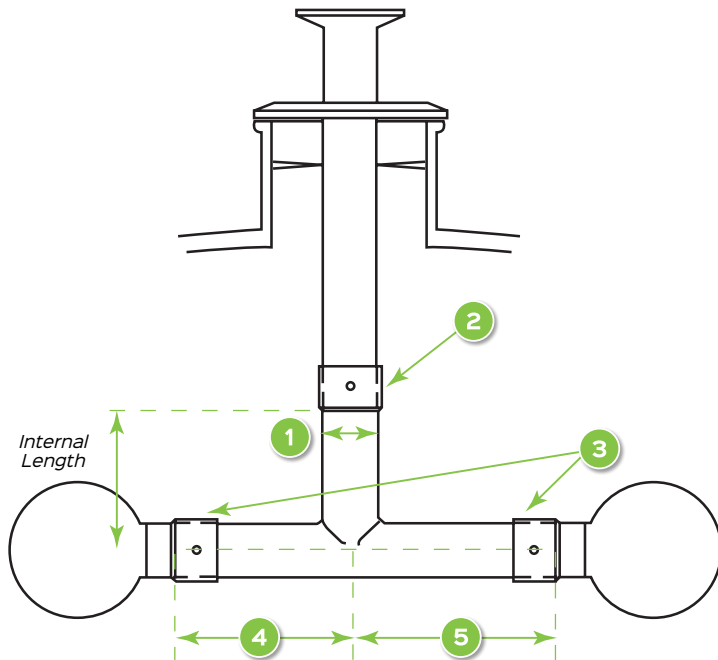

- 1 Tube Diameter
- 2 Supply Tube Connection
- 3 Spray Ball Connection
- 4 Left Leg Length
- 5 Right Leg Length

Tube Diameter (selection 1)	Standard Internal Length
0.75"	1.0"
1.0"	1 ¹¹ / ₁₆ "
1.5"	2 ¹³ / ₃₂ "
2.0"	2 ¹¹ / ₁₆ "

NOTE: Prior to 2021, dimension bubble numbers 4 and 5 (corresponding to model key #'s 10-13) were measured to center of spray device.

Supply Tube & Double Ball Tee Accessories

Static Spray Ball Clips (316ss)

Description	Part #
Hair Pin Clip for 0.50" SC ¹	321443
Wraparound Clip for 0.75" SC	321554
Wraparound Clip for 1.00" SC	321555
Wraparound Clip for 1.50" SC	321556
Wraparound Clip for 2.00" SC	321557
Wraparound Clip for 2.50" SC	321658

¹0.50" Clip diameter does not conform to 3-A standard.

NOTE: One clip is included with every spray ball with slip collar connection.



Static Spray Ball Clip

Tri-Clamp (TC) Clamps

Connection Size	Standard Clamp Part #
0.50" / 0.75"	020224
1.5"	020912
2.0"	020913
2.5"	020914
3.0"	020915
4.0"	020916
6.0"	025686



Standard Clamp

DISTRIBUTED BY

HARCO
ENTERPRISES LTD.

1-800-361-5361