



HARCO
ENTERPRISES LTD.

Since 1964

INDUSTRIAL STAINLESS STEEL PRESSURE GAUGES CATALOG



www.harcosupply.com





Supply House to the Processing Industries Since 1964

Trusted supply house of sanitary processing equipment, parts and supplies for the dairy and food, brewery, beverage and pharmaceutical industries.

Harco Enterprises offers a diverse line of sanitary and hygienic processing equipment, parts and supplies including pumps, sanitary valves, separators, homogenizers, gaskets and fittings, sanitary hoses, and instrumentation as well as a variety of other products from world leading manufacturers such as Alfa Laval, Ampco, Tetra Pak, Burkert, Tri-Clover, Remco, Vikan, Carlisle, Haynes, Strahman, and more.

These products are distributed to dairy, food, beverage processing facilities as well as the pharmaceutical, brewing, and fisheries industries throughout North America.

Many of our products are customized in design due to strict sanitary and hygienic standards, and all are built to stand up to the demands of high production environments. Resourcefulness and quick delivery are important to you, and Harco always provides both.

Check out our large collection of equipment, parts and supplies, including our line of color-coded products available.

Visit our website today at www.harcosupply.com

INDUSTRIAL STAINLESS STEEL PRESSURE GAUGES

INSTA-FLOW

The Industrial Stainless Steel Pressure Gauge is an extremely durable yet accurate all stainless steel industrial pressure gauge. We offer this gauge with NPT connections in ranges from 30" Hg vacuum to 23,000 psi in either a 2½" (63mm) or 4" (100mm) dial face. Quality products, and service to back them up, are the keys to our success and yours.

FEATURES

316L Stainless Steel Construction on all wetted surfaces assures maximum corrosion resistance.

304 Stainless Steel Case for durability even in the roughest environments.

Waterproof Construction throughout to allow the gauge to be submersed for cleaning.

C.I.P. - can be cleaned in place for convenience and eliminates the possibility of damage from mishandling.

Pressure Ranges from 30" Hg vacuum to 23,000 psi.

True Zero is standard on all gauges. The pointer is not pinned at zero and there is not a large zero block. This lets the operator know the pressure is truly zero and gives the most accurate pressure reading available.

Re-zero Feature is optional on all gauges.

Glycerin Fill is standard on all gauges unless requested otherwise. This protects the gear mechanism with continuous lubrication against vibration and wear caused by applications with vibration or pressure pulsations.

140°F (60°C) Maximum process temperature Please consult factory when ordering for higher temperature applications.

Immediate Availability from stock for all pressure gauges.

Experienced Engineers are available to answer questions and solve difficult application problems. Unparalleled Customer Service where the customer is always right and we are not happy until the customer is satisfied. No restocking charges and 30 day no-risk trials are always available.

SPECIFICATIONS

Accuracy	±1.5% of Full Scale
Over Range Capability	30%
Wetted Surfaces	316L Stainless Steel
Case Material	304 Stainless Steel
Dial Sizes	2½"(63mm) or 4"(100mm) Dia.
Lens Material 2½"	Polycarbonate
Lens Material 4"	Safety Glass or Polycarbonate
Temp. Limits	-40°F (-40°C) to 140°F (60°C)
Standard Fill	Food Grade Glycerine
Rezero Feature (on pointer)	Optional
Shipping Weight 2½"	Approx. 1 lbs. (.5kg)
Shipping Weight 4"	Approx. 2 lbs. (1kg)

**For high temperature applications please consult Harco.*

AVAILABLE RANGES (psi)

0 to 15psi	0 to 400 psi	30" to 0 psi
0 to 30 psi	0 to 600 psi	30" to 15 psi
0 to 60 psi	0 to 1,000 psi	30" to 30 psi
0 to 100 psi	0 to 3,000 psi	30" to 60 psi
0 to 160 psi	0 to 10,000 psi	30" to 100 psi
0 to 200 psi	0 to 14,500 psi (2½" only)	30" to 150 psi
0 to 300 psi	0 to 23,000 psi (2½" only)	

Standard scales are in PSI only, dual scale PSI-BAR, PSI-KG/cm², metric and other scales available upon request.

AVAILABLE FITTINGS

¼-18 NPT for 2½" (63mm).
¼-18 NPT or ½-18 NPT for 4" (100mm).
For other fittings please consult Harco.

AVAILABLE MOUNTINGS

Bottom, Top, Left Side, Right Side and Back mount.



INDUSTRIAL STAINLESS STEEL PRESSURE GAUGES

2 1/2" GAUGE
(63mm)

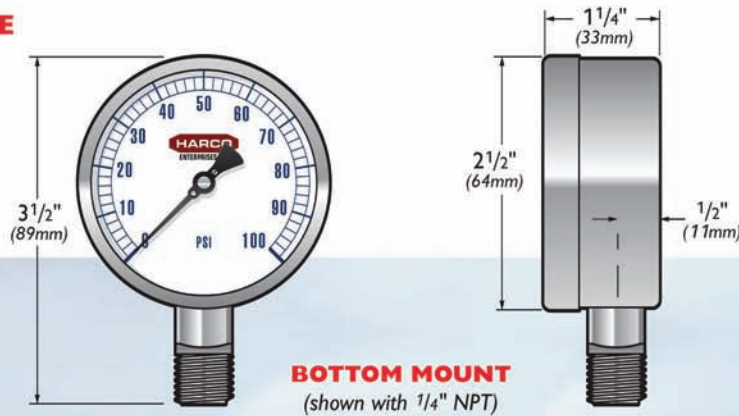

BOTTOM MOUNT
(shown with 1/4" NPT)

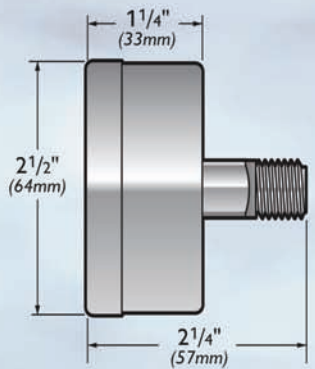

BACK MOUNT
(shown with 1/4" NPT)



RIGHT SIDE MOUNT
(shown with 1/4" NPT)



TOP MOUNT
(shown with 1/4" NPT)

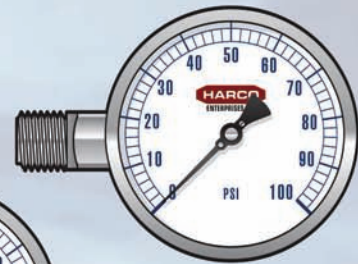

LEFT SIDE MOUNT
(shown with 1/4" NPT)

4" GAUGE
(100mm)

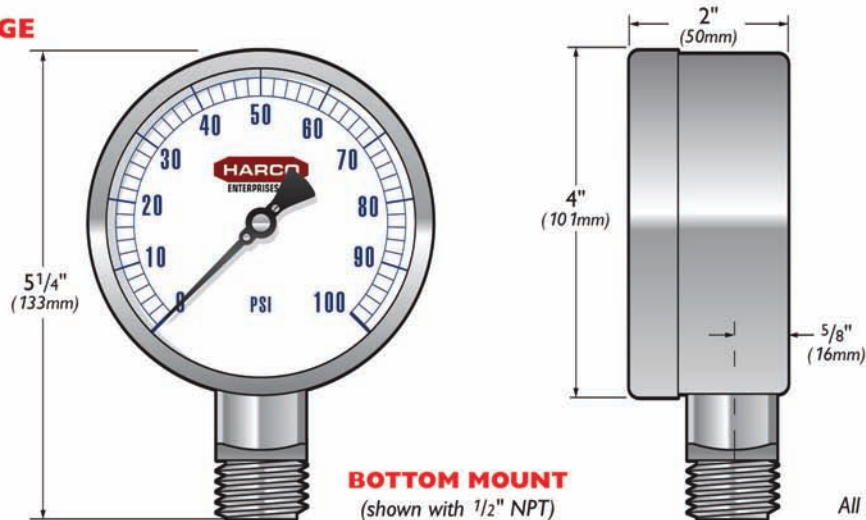

BOTTOM MOUNT
(shown with 1/2" NPT)

All dimensions are approximate.

INDUSTRIAL STAINLESS STEEL PRESSURE GAUGES

ORDERING INFORMATION

Below are typical examples of models with their descriptions.

EXAMPLE 1:**2N - E - ¼NPT - GF - BT**

Describes a 2½" (63mm) Insta-Flow Pressure Gauge, 0 to 160 psi, ¼" NPT fitting, glycerine filled case, bottom mounted.

EXAMPLE 2:**2N - DB - ¼NPT - GF - BT**

Describes a 2½" (63mm) Insta-Flow Pressure Gauge, 0 to 100 psi/0 to 7 BAR, ¼" NPT fitting, glycerine filled case, bottom mounted.

EXAMPLE 3:**4N - E - ½NPT - GF - BK**

Describes a 4" (100mm) Insta-Flow Pressure Gauge, 0 to 160 psi, ½" NPT fitting, glycerine filled case, back mounted.

EXAMPLE 4:**4N - GK - ¼NPT - GF - RT**

Describes a 4" (100mm) Insta-Flow Pressure Gauge, 0 to 300 psi/0 to 21 Kg/cm², ¼" NPT fitting, glycerine filled case, right side mounted.

MODEL NUMBER CONSISTS OF:

SERIES	PRESSURE RANGE	FITTING	FILLED CASE	MOUNT
2N	D	¼NPT	GF	BT

Please make a selection from each category below:

SERIES

2N - 2½" (63mm) Insta-Flow Gauge

4N - 4" (100mm) Insta-Flow Gauge

PRESSURE RANGE*

A 0 to 15 psi (1 BAR)

B 0 to 30 psi (2 BAR)

C 0 to 60 psi (4 BAR)

D 0 to 100 psi (7 BAR)

E 0 to 160 psi (11 BAR)

F 0 to 200 psi (14 BAR)

G 0 to 300 psi (21 BAR)

H 0 to 400 psi (28 BAR)

I 0 to 600 psi (41 BAR)

K 0 to 1,000 psi (70 BAR)

M 30" Hg to 30 psi (-1 to 2 BAR)

N 30" Hg to 60 psi (-1 to 4 BAR)

O 30" Hg to 100 psi (-1 to 7 BAR)

P 30" Hg to 150 psi (-1 to 10 BAR)

U 0 to 3,000 psi (205 BAR)

W 0 to 10,000 psi (700 BAR)

14500 0 to 14,500 psi (1,00 BAR)**

23000 0 to 23,000 psi (1,600 BAR)**

J 30" Hg to 0 psi (-1 to 0 BAR)

L 0" Hg to 15 psi (-1 to 1 BAR)

M 30" Hg to 30 psi (-1 to 2 BAR)

N 30" Hg to 60 psi (-1 to 4 BAR)

O 30" Hg to 100 psi (-1 to 7 BAR)

P 30" Hg to 150 psi (-1 to 10 BAR)

FITTINGS

¼NPT ¼-18 Male Pipe Thread

½NPT ½-14 Male Pipe Thread (4" only)

FILLED CASE

GF Glycerine Filled

SF Silicone Filled

NF No Fill (Dry Case)

04 Other (Specify)

MOUNT

BT Bottom Mount

BK Back Mount

TP Top Mount

RT Right Side Mount

LF Left Side Mount

* Standard scales are in PSI only. For dual scales, after the pressure range add letter B for PSI/BAR, K for PSI/Kg/cm², P for PSI/KPa.

** Available in 2½" dial size only.



Product Line Card

Supply House to the Processing Industries Since 1964

Harco partners with leading manufacturers in the industry to bring you an innovative range of sanitary and hygienic processing equipment and supplies. With experience in design, manufacturing and support, our partners are selected for their quality, reliability, and advanced products.

