



DISTRIBUTED BY



1-800-361-5361

Alfa Laval Front 8

Gasketed plate heat exchanger for hygienic applications

Introduction

Alfa Laval FrontLine is the premium range of heat exchangers used in dairy, food, beverage and other hygienic applications requiring gentle product treatment, long operating times or superior cleanability. A large range of plate and gasket types is available.

The Clip plate has a chevron type of plate pattern designed for hygienic conditions. The entry points, the distribution area and the shape and pressing depth of the plate pattern give optimal performance.

WideStream plates with special plate pattern and a limited number of contact points are available for viscous products and products containing pulp and fibres.

In addition to normal single plate configuration, this model is also available with Gemini double wall plates. Gemini plates are fully cleanable and accessible and are used as an extra precaution to avoid intermixing of fluids.

Applications

- Biotech and Pharmaceutical
- Food, Dairy and Beverages
- Home and Personal care

Benefits

- Superior hygienic safety – plates designed for food applications
- Gentle treatment of sensitive products
- Uncompromising cleanliness
- Flexible configuration – possible to rebuild the heat exchanger

Features

Every detail is carefully designed to ensure the highest hygienic standards, gentle product treatment and efficient cleaning. Selection of available features, depending on configuration some features may not be applicable:



- Five-point alignment
- Corner guided alignment system
- Chocolate pattern distribution area
- T-bar roller
- Clip-on gasket

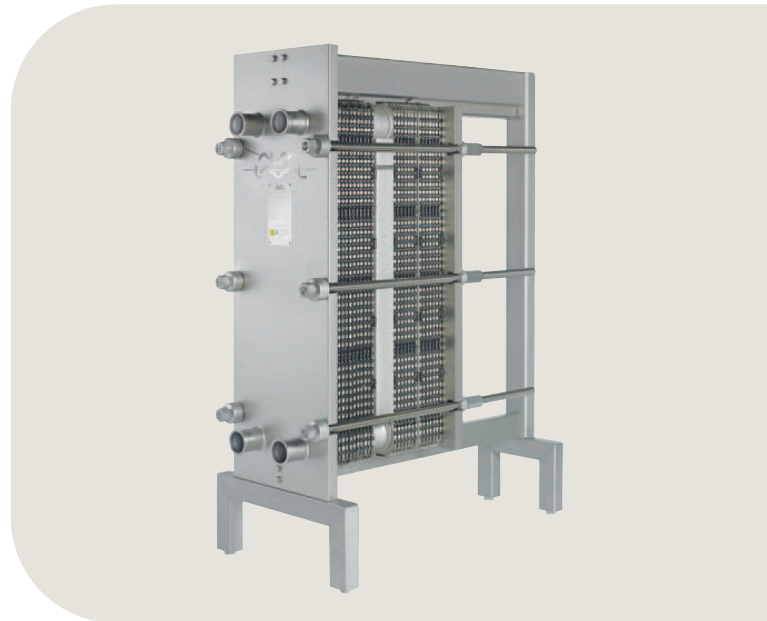

- Leak chamber
- Bearing boxes
- Fixed bolt head
- Key hole bolt opening
- Lock washer
- Pressure plate roller
- Connection plate roller
- Interchangeable corners
- Adjustable feet
- 2-point feet support on column
- Tightening bolt cover

Alfa Laval 360° Service Portfolio

Our extensive service offering ensure top performance from your Alfa Laval equipment throughout its life cycle. The Alfa Laval 360 Service Portfolio include installation services, cleaning and repair as well as spare parts, technical documentation and trouble shooting. We also offer replacement, retrofit, integrity testing, monitoring and much more.

For information about our complete service offering and how to contact us - please visit www.alfalaval.com/service.

Dimensional drawing

Measurements mm (inches)

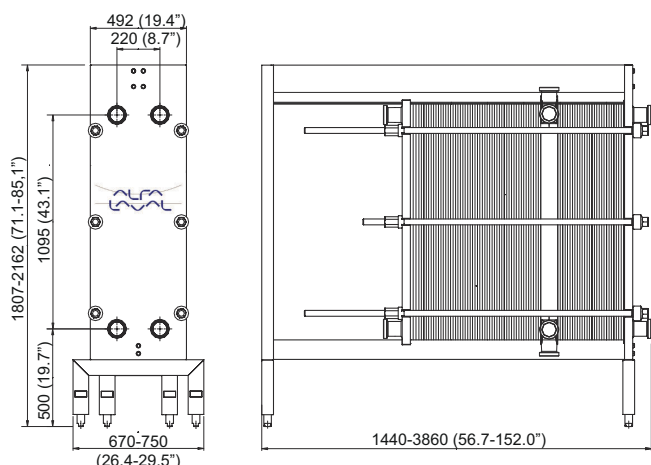

Connections

DIN, SMS, Tri-CLAMP, BS/RJT and IDF/ISO male parts.

General remarks for technical information

- The global offering presented in this leaflet may not be available for all regions
- All combinations may not be configurable

Technical data

Plates	Type	Free channel, mm (inches)
Clip 8	Single plate	4.0 (0.16)
Clip 8-G	Gemini (hygienic), Double wall	4.0 (0.16)
Clip 8-WS	WideStream	4.0 (0.16)

Materials

Heat transfer plates	316/316L, 254 Ti
Field gaskets	NBR, EPDM
Connections	Acid proof stainless steel
Frame and pressure plate	Solid stainless steel, clad stainless steel or surface coated

Other materials may be available on request.

The plate heat exchanger can be manufactured according to 3A certification.

The gaskets are produced in compliance with the regulations of FDA.

Operational data

Frame type	Max. design pressure barg (psig)	Max. design temperature °C (°F)
RM, pvcALS	10.0 (145)	150 (302)
RM, PED	10.0 (145)	150 (302)
RH, pvcALS	16.0 (232)	150 (302)
RH, PED	16.0 (232)	150 (302)
RD, PED	21.0 (304)	150 (302)

Extended pressure and temperature rating may be available on request.

This document and its contents are subject to copyrights and other intellectual property rights owned by Alfa Laval AB (publ) or any of its affiliates (jointly "Alfa Laval"). No part of this document may be copied, re-produced or transmitted in any form or by any means, or for any purpose, without Alfa Laval's prior express written permission. Information and services provided in this document are made as a benefit and service to the user, and no representations or warranties are made about the accuracy or suitability of this information and these services for any purpose. All rights are reserved.

How to contact Alfa Laval

Up-to-date Alfa Laval contact details for all countries are always available on our website at www.alfalaval.com