



DISTRIBUTED BY



1-800-361-5361

Alfa Laval HL12

Gasketed plate heat exchanger for hygienic applications

Introduction

Alfa Laval Hygienic line is a range of premium heat exchangers specifically developed for pharmaceutical, dairy, beverage, brewery and other industries where hygiene standards must not be compromised.

The optimal flow distribution ensures superior cleanability and long operating times. Our special plate pattern provides gentle treatment of delicate products. Several innovative design features of both plate and gasket enable safe food production.

Applications

- Food, Dairy and Beverages
- Home and Personal care

Benefits

- Superior hygienic standards – plates designed with food safety as top priority
- Gentle treatment of sensitive products
- Uncompromising cleanliness
- Superior distribution for long running hours
- Gives a plate package with perfect match between the plates
- Flexible configuration – possible to rebuild the heat exchanger

Features

Every detail is carefully designed to ensure the highest hygienic standards, gentle product treatment and efficient cleaning. Selection of available features, depending on configuration some features may not be applicable:



- Five-point alignment
- SmoothPort™
- ClipGrip™ gasket attachment
- Hygienic leak chamber
- Interchangeable corners
- Hygienic adjustable feet
- EquiFlow™
- CleanChannel™

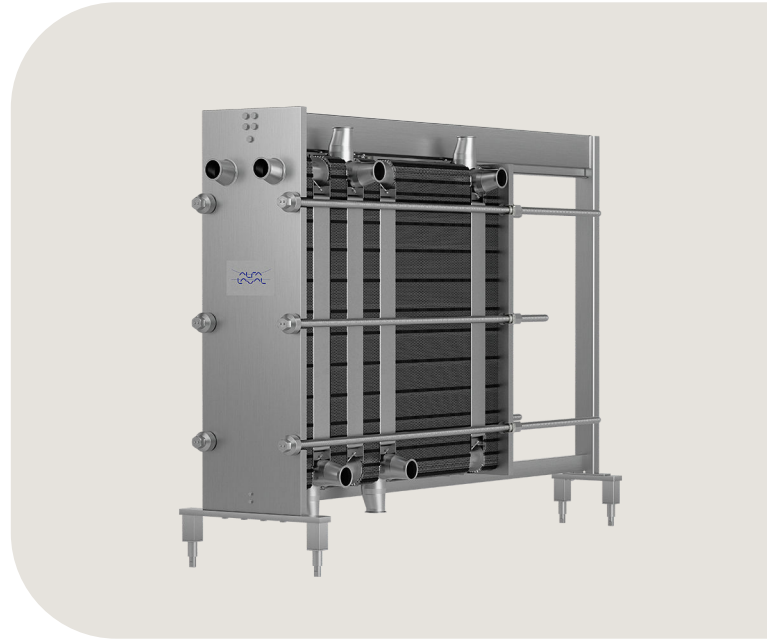

Alfa Laval 360° Service Portfolio

Our extensive service offering ensure top performance from your Alfa Laval equipment throughout its life cycle. The Alfa Laval 360 Service Portfolio include installation services, cleaning and repair as well as spare parts, technical documentation and trouble shooting. We also offer replacement, retrofit, integrity testing, monitoring and much more.

For information about our complete service offering and how to contact us - please visit www.alfalaval.com/service.

Dimensional drawing

Measurements mm (inches)

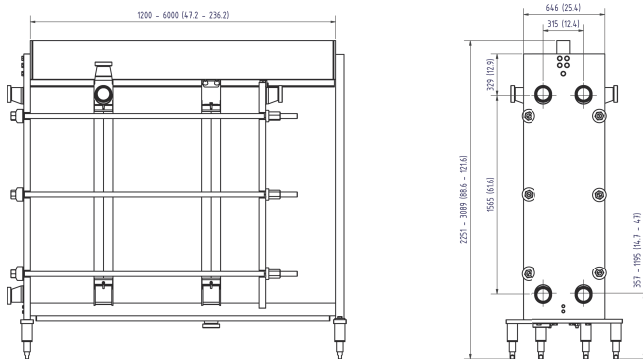

Technical data

Plates	Type	Free channel, mm (inches)
P	Single plate	3.2 (0.13)

Materials

Heat transfer plates	
Field gaskets	NBR, EPDM
Frame and pressure plate	Cladded stainless steel Carbon steel, epoxy painted

Other materials may be available on request.

The plate heat exchanger can be manufactured according to 3A certification.

The gaskets are produced in compliance with the regulations of FDA.

Operational data

Frame type	Max. design pressure barg (psig)	Max. design temperature °C (°F)
FM, PED	10.0 (145)	160 (320)
FM, pvcALS	10.0 (145)	160 (320)
SG, PED	16.0 (232)	160 (320)
SG, pvcALS	16.0 (232)	160 (320)

Extended pressure and temperature rating may be available on request.

Connections

Clamp, SMS, DIN (unions and flanges), BS/RJT, and IDF/ISO.

General remarks for technical information

- The global offering presented in this leaflet may not be available for all regions
- All combinations may not be configurable

This document and its contents are subject to copyrights and other intellectual property rights owned by Alfa Laval AB (publ) or any of its affiliates (jointly "Alfa Laval"). No part of this document may be copied, re-produced or transmitted in any form or by any means, or for any purpose, without Alfa Laval's prior express written permission. Information and services provided in this document are made as a benefit and service to the user, and no representations or warranties are made about the accuracy or suitability of this information and these services for any purpose. All rights are reserved.

How to contact Alfa Laval

Up-to-date Alfa Laval contact details for all countries are always available on our website at www.alfalaval.com